

) acoustic

commons (

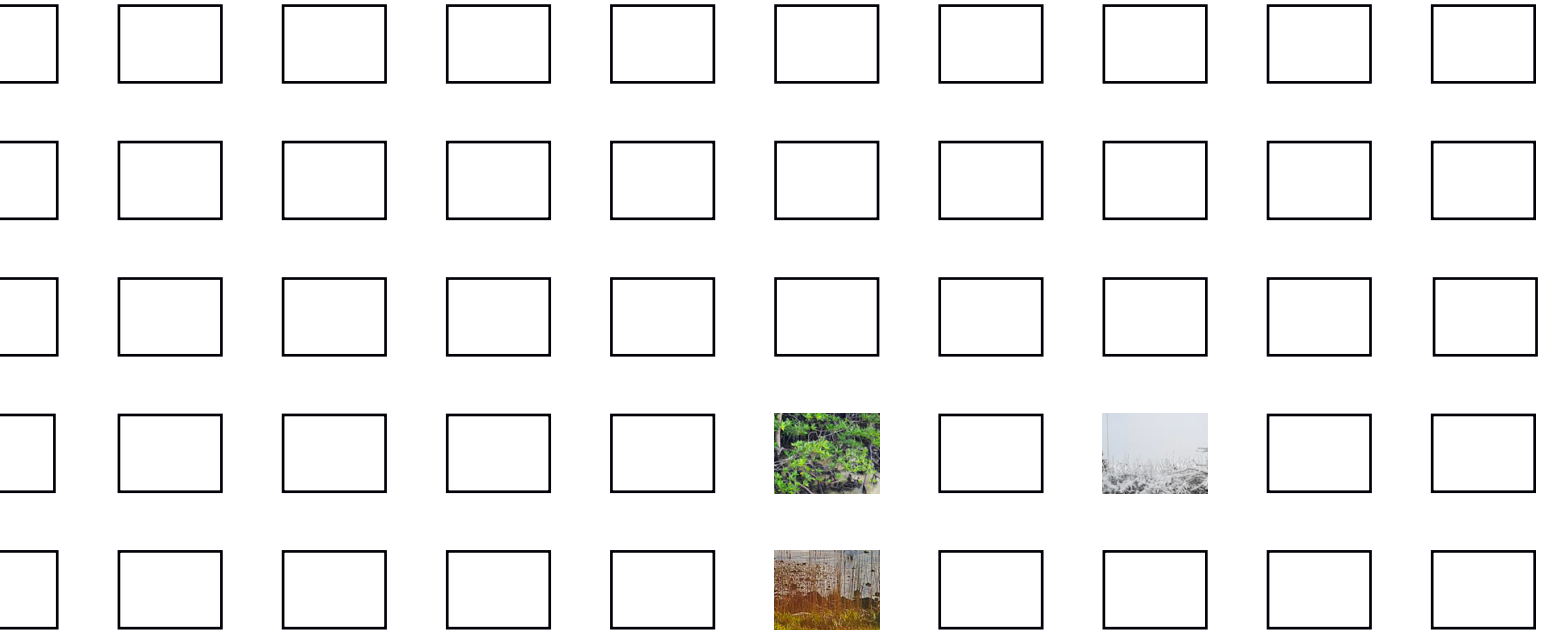

BOOKLET 3

Creative Technical Workshop #2

Online

25/01/21 –
30/01/21



Acoustic Commons invites participants to join a one-week workshop, taking place online and across project spaces in Aix (Locus Sonus), Ljubljana (CONA), Barrow (Full of Noises), London (Soundcamp), with other locations to join.

The workshop focuses on skills exchanges and digital capacity for live environmental streaming in Year 2 of Acoustic Commons, with a focus on ‘off-grid’ working.

Participants can connect to a project space in person (where possible within local restrictions) or remotely via networked online sessions at the start/end of each day. Participants will be invited to share their streams, projects and practice.

Areas covered will include:

- Using streams with Pure Data
- Off-Grid audio streaming
- Using streams within New Atlantis
- Using the Locuscast mobile app
- Hardware review - Raspberry Pi hats, audio interfaces etc
- Making microphones
- Listening groups

Acoustic Commons is a collaboration between four arts organisations and a range of associate partners, each with close links to a specific site of cultural and/or natural heritage value. The project draws upon and develops those links, through a range of creative and technical approaches and innovative ways to engage with audiences and places.

Mort Drew
 Maria Papadomanolaki
 Lisa Hall
 Jonathan Kemp
 Claudia Martinho
 RL Wilson
 David Shepherd
 beepblip / Ida
 Hiršfenfelder
 Clayton Jackson
 Lia Mazzari
 gobscure
 Karina Townsend
 Alisa Oleva
 Jez riley French
 Lucinda and Chris
 Kate Genevieve
 Alyssa MOxley
 Signe Liden
 Michel jacobs
 Josephine Dickinson
 Nicolau Centola
 Rizwan Mirza
 Alice Angus
 Rupert Cox
 Julia Merino Calleja
 Sarah Dalrymple
 Lee Jackson
 Katerina Tzedaki
 cedric maridet
 Martin Scaiff
 Emma Welton
 Guy Van Belle
 Lee Jackson
 Alex Albert
 karen mair
 Ed Baker
 Magz Hall
 meira asher
 Thomas Evdokimoff
 Rupert Cox
 Dave Sohanpal

Emilie
 Saurabh Levin
 Spyros Roumeliotis
 Panos Amelidis
 Stelios Giannoulakis
 Natalie sharp
 George Ridgway
 Kathryn Tovey
 Dean Powell
 David Halsell
 Lorenzo Prati
 Sophie Giblin
 James Wilkie
 Fergus
 Ingrid Plum
 Veronica Salinas
 Beatrice Alvestad
 Lopez
 Michael Speers
 Melissa Gonzales
 Teresa Connors
 Cristian Pinto
 Fernandez
 Pietro Bardini
 Giorgos Stavridis
 Stephen Shiell
 Hannah White
 Vince Hancock
 Tosca
 Sing
 James Brown
 Margarethe
 Maierhofer-Lischka
 Viktoria
 Max Sister
 Cheng Nga Yan
 Ilias Mavromatis
 Hugh Livingston
 Bridget Bell
 Zijun FENG
 Stuart Bannister
 Mélia Roger

Caddie Brain
 Edy Fung
 Leah Barclay
 Andromachi Vrakatseli
 william martin
 Rob Mackay
 Matt Rose
 Pekka Matilainen
 Kate Galloway
 Andrea Dancer
 Afraaz Mulji
 James Bagshaw
 Mike Challis
 Kristine Diekman
 David de la Haye
 Elise Cavicchi
 Christopher Steenson
 Anthi
 Sourav Saha
 Cedric Parizot
 Ainolnaim Azizol
 Darren Copeland
 Alberto Rizzo
 Duriye Nasuhoglu
 Vasiliki Papageorgiou
 Kate Paxman
 Myles
 Giorgos Gargalas
 Emilio Pascual
 Jonathan Freiman
 Samedha
 Esther Salmona
 Carlos Choconta
 Alba Perset
 Kathryn Marshall
 David Carpenter
 Auguste Oldham
 Jacek Smolicki
 Giulia Francavilla
 Alejandro Valencia-
 Tobon
 Shangyunwu

Mike Bullock
 Marina Stavrou
 Christina
 Macarena
 Natalie Pollard
 Michelle Marie Lewis
 King
 Sophie Jung
 Viviana carlos
 Angela McArthur
 Sid Mitzlaff
 Catherine Fletcher

Date	CET (-1hr for UK)	Hardware (Transmission)	Mobile (Streaming, listening, performance)	Software (Reception)
Mon 25th - Intros - Make Day 1	10:00 - 13:00	Introduction to Acoustic Commons project and workshop strands - Streambox building	Introduction to Acoustic Commons project and workshop strands	Introduction to Acoustic Commons project and workshop strands
	13:00 - 14:00	Lunch	Lunch	Lunch
	14:00 - 17:00	Tech clinic (2-3pm) and more streambox building	Locuscast	New Atlantis and Pure Data
	20:00 -	Evening session - sounds / voices of AC	Evening session - sounds / voices of AC	Evening session - sounds / voices of AC
Tue 26th - Make Day 2	10:00 - 13:00	Microphone building	Locuscast	New Atlantis and PD
	13:00 - 14:00	Lunch	Lunch	Lunch
	14:00 - 17:00	Tech clinic (2-3) and more mic building	Locuscast	New Atlantis and PD
	20:00 -	Evening session - sounds / voices of AC	Evening session - sounds / voices of AC	Evening session - sounds / voices of AC
Wed 27th - Make Day 3	10:00 - 13:00	Off grid streambox building	Locuscast	New Atlantis and PD
	13:00 - 14:00	Lunch	Lunch	Lunch
	14:00 - 17:00	Off grid tech clinic (2-3) and more solar	Locuscast	New Atlantis and PD
	20:00 -	Evening session - sounds / voices of AC	Evening session - sounds / voices of AC	Evening session - sounds / voices of AC
Thu 28th - Listening Day	10:00 - 13:00	Collaborations and listening	Collaborations and listening	Collaborations and listening
	13:00 - 14:00	Lunch	Lunch	Lunch
	14:00 - 17:00	Collaborations and listening	Collaborations and listening	Collaborations and listening
	20:00 -	Evening session - sounds / voices of AC	Evening session - sounds / voices of AC	Evening session - sounds / voices of AC
Fri 29th - Sharing Day	10:00 - 13:00	Preparations for sharing	Preparations for sharing	Preparations for sharing
	13:00 - 14:00	Lunch	Lunch	Lunch
	14:00 - 17:00	Sharing / Conclusion	Sharing / Conclusion	Sharing / Conclusion
	20:00 -	Evening session - sounds / voices of AC	Evening session - sounds / voices of AC	Evening session - sounds / voices of AC

Please note that all times are in Central European Time (CET).

The week is designed to let people drop in and out. However, it will be easiest to get orientated if you are able to attend the opening short introductions to the project and workshop strands from 10AM CET on Monday 25th. During the week, it is advisable to try to join at the start of a session (10:00 CET or 14:00 CET). Each session will start with a summary of progress so far and what the next session aims to cover.

The workshops will be organised into 3 strands:

- Hardware (building streaming devices and microphones)
- Mobile (streaming using the Locuscast app)
- Software (working with live streams in Pure Data and the New Atlantis virtual environment)

They will partly practical / instructive and partly self directed, with time to go off and try things out, and later come back to the group.

The program is designed be useful if you don't have all the parts, or only some! Some parts of the program will use other platforms, such as New Atlantis and the Locus Sonus soundmap. We will link to them from Discord and the event page.

A 'streaming clinic' will be open across channels after lunch.

A complementary listening program will run each evening from 20:00 CET.

During the evening program, and throughout the week, there will be opportunities to hear from practitioners working with live audio streams, and to contribute.

There will be a sharing session on Friday.

Watch the Discord and the event page for updates, including video recorded from earlier in the program: <http://acousticcommons.net/events/ctw.html>

Introduction

10:02 CET
Glenn Boulter:
introduction to the project.

Grant Smith:
schedule, workshop groups

(resolving tech issues)

Salons Textuels

- #welcome
- #new-atlantis
- #pure-data
- #locuscast
- #streambox-building
- #microphone-building
- #link-to-listen-streams

Salons Vocaux

- Welcome
- New Atlantis
- Streambox Building
- Microphone Building
- Locuscast
- Chill and Listen

10:30 CET
Peter Sinclair:
introduction to New
Atlantis, LocusCast, Pure
Data.

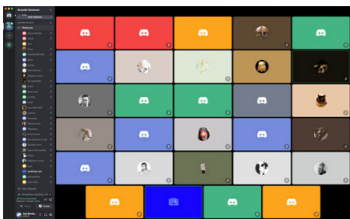
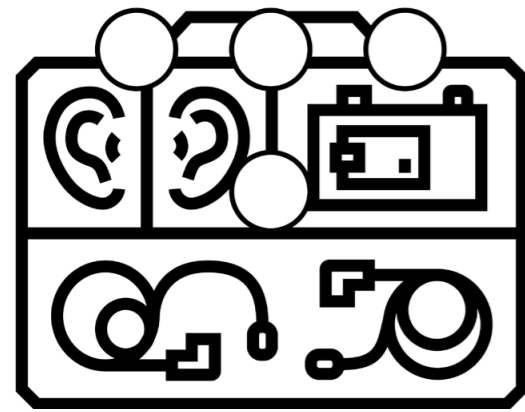

Streambox Building



11:00 CET
Equipment check



Microphone



Synthetic fur for
windshield

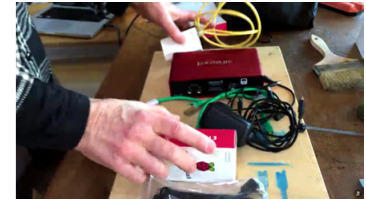

12:15 CET
Interior
12:33 CET
Raspberry Pi demo



Drilling the casing



Cover: slate / roofing tile,
etc.

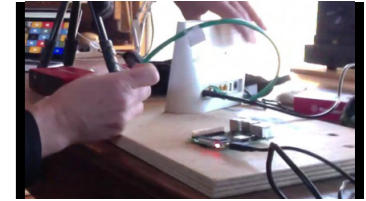

12:42 CET
Connecting the Pi to a
router

Focusrite soundcard



Recipe:
<https://paper.dropbox.com/doc/Streambox-with-Focusrite-Soundcard-y6K4xLU-HuP31BKqhINoND>

Parts + costs:
<https://docs.google.com/spreadsheets/d/1wNMExE-gdEP-GXNTj8LVYkjkAQB-GRDdb3AcWSyg-IN9Y/edit#gid=1146240478>



Raspberry Pi

Q: Where to get fur?
A: EU Fabrics Ltd.

13:00 CET

New Atlantis



14:15 CET
 New Atlantis is a shared (multi-user) online virtual world dedicated to audio experimentation and practice:
<https://jonlab.github.io/NewAtlantisWeb/index.html?spawn=acc>

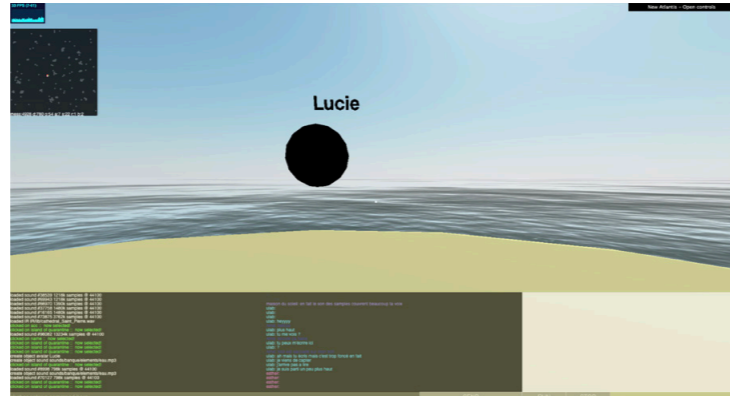
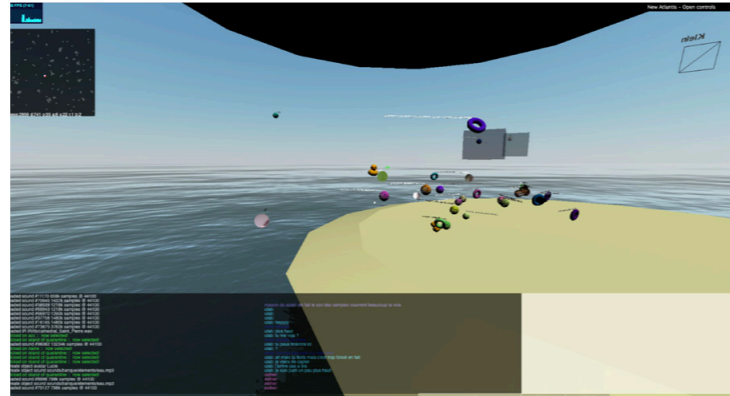
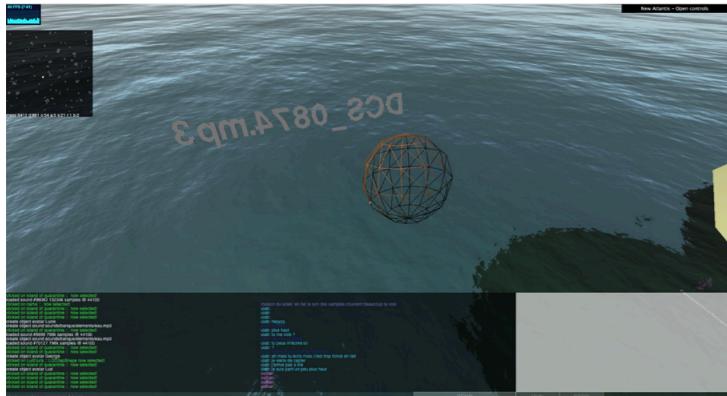

LocusCast

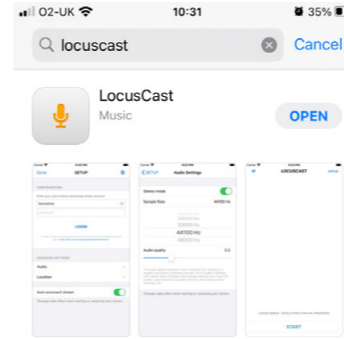

11:31 CET
 LocusCast is a mobile audio streaming app for the Locustream project and Soundmap.

Locus Sonus soundmap



For discussion:
 'why?'
 'where?'
 'what are the benefits?'

https://soundtent.org/streaming_recipes.html

Ways to stream live sound



Microphone Building

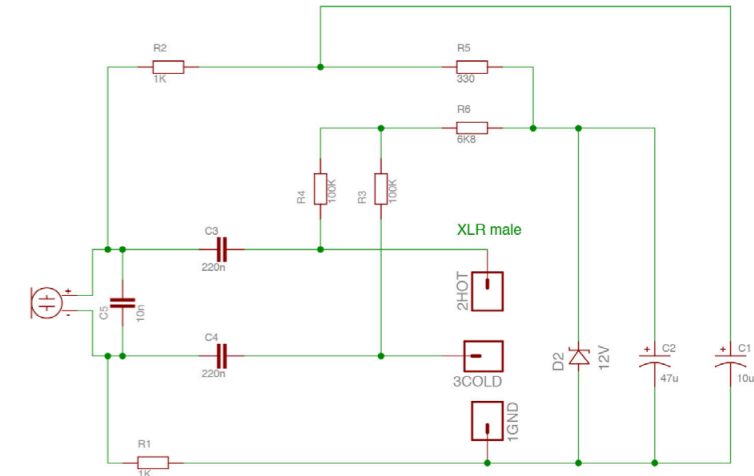
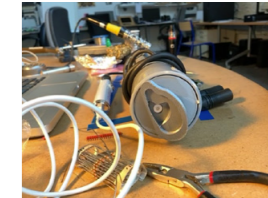
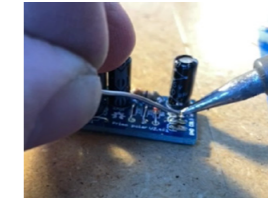
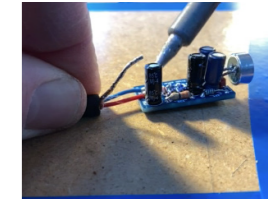

Pure Data

Pure Data is an open source visual programming language for multimedia.

remember to switch the audio on before streaming|

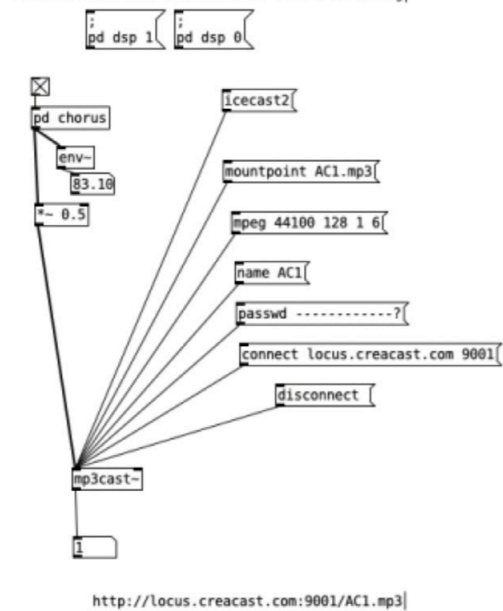

<http://locus.creacast.com:9001/AC1.mp3>

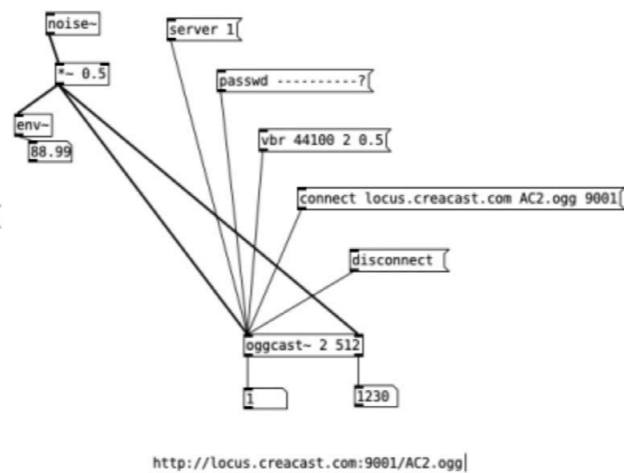

<http://locus.creacast.com:9001/AC2.ogg>

Listening Session

Grant at 18:48
http://locus.creacast.com:9001/acoustic_commons_workshop_2
 ..
 dawn at 19:11
 doesn't sound very locked down in kolkata
 anybody know if these are crows calling?
 PekkaMatilainen at 19:18
 Sounds like a crow
 the horn is very rare here, you only hear it in an emergency
 dawn at 19:21
 i'm surprised how busy it is given the hour, and covid
 PekkaMatilainen at 19:22
 Is it UTC+5.30?
 dawn at 19:23
 thought so yes
 dawn at 19:24
 where are you listening from?
 PekkaMatilainen at 19:24
 F[in]nland
 Grant at 19:24
 ..
 The house crow (*Corvus splendens*), .. is .. found in many parts of the world, where they arrived assisted by shipping..
 PekkaMatilainen at 19:25
 the locals are perhaps a little plumper, *Corvus corone cornix*
 Varis (*alalajiksi tulkittuna Corvus corone cornix*) on ihmiskasutuksen lähellä viihtyvää lintu..
 dawn at 19:27
 ..a[] live audio tour of crows in different regions could be good, imo
 ..

yantantethra at 19:30
 We have a group (about 20) of Jackdaws visit us each morning for breakfast.
 ..
 We feed them dried meal worms and bits from the kitchen.
 ..
 PekkaMatilainen at 19:34
 Here ravens and crows get food only from the landfill and there Owls hunt them
 dawn at 19:34
 maybe the kolkata ones have gone to sleep now
 ..
 workshop cam at 19:43
 yes
 there s a stream in W Africa!
 did somebody listen?
 Roy at 19:44
 The Corneilles and dogs are awakening my cats-on-the-bed in the south of France...
 ..
 ears as sonars
 workshop cam at 19:45
 ..
 is it 2 years now that Sukanta has been operating this stream?
 dawn at 19:48
 maybe more
 workshop cam at 19:48
 a kind of familiarity begins from listening to this part of the city by his house
 at night
 i think more - yes
 workshop cam at 19:51
 earlier.. there was this discussion

about streams and privacy
 I remember asking Sukanta about it in the case of this stream
 he said private / public was not clear cut
 PekkaMatilainen at 19:55
 I'm just planning to start Stream
 63 ° 36'03.4 "N 26 ° 53'16.3" E a few more components still need to be acquired.
 Hopefully within a month.
 dawn at 19:55
 streams are outward facing at least
 ..
 yantantethra at 20:02
 I agree with you
 Dawn - listening in the 3rd person.
 workshop cam at 20:03
 or a slippage between persons?
 ..
 dawn at 20:03
 can be uncanny to to catch yourself on there..
 or sometimes if you have a mic on and mixing with remote stream
 once i clapped and it started raining in asia
 ..
 dawn at 20:06
 .. amacher talked about synchronicity

using streams to learn about space and rhythm in a general sense
 workshop cam at 20:08
 common time
 dawn at 20:08
 not specific sounds
 but patterns maybe
 workshop cam at 20:08
 yes

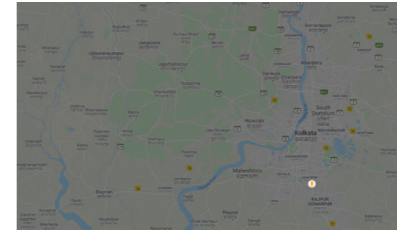

..
 workshop cam at 20:51
 .. even listening to the stream from your own place, with lag, there is something added, through displacement
 yantantethra at 20:52
 Is that a cocker[e]l
 workshop cam at 20:53
 it is!
 arrière-pays
 Roy at 20:59
 I wanted to say,

I have to leave you now. Lovely stream, v interesting discussion. See you in the morning.
 workshop cam at 21:02
 ok for sure - good night, Andrew
 Roy at 21:03
 have a good night
 yantantethra at 21:03
 Good night all. :slight_smile:
 Roy at 21:05
 yes what slides and hangs with our own soundscape and creates some holes, vacant lands, very mysterious about streams
 workshop cam at 21:05
 hmm yes
 .. gaps and voids
 like now, if feels very full of holes
 Roy at 21:09
 with the memory and echo of the dog, a silence is created
 workshop cam at 21:09
 ha
 so time partly proceeds by accumulating these omissions
 you do these kind of micro retrospectives
 rather than perceiving change 'directly'
 Mort Drew at 21:14
 I'm currently listening through the tv in our living room - the sound is expanding like a gas and mixing with the sounds of my housemate sneezing and walking around next door. The sound is domesticated by the context of its reproduction.
 dawn at 21:14
 "a well staring at the sky"
 Roy at 21:15

this multiplied distance brings about connections, erasures, condensation
 yes
 coulisses
 workshop cam at 21:01
 ah nice: the wings, maybe the backstage of a documentary
 Roy at 21:02
 yeah
 yantantethra at 21:02

that's it, i suppose it's one of the reasons when to turn off a stream it's almost painful or strange physical sensation
Mort Drew at 21:16
Yes! I'm always amazed by that very real physical sensation of separation
Roy at 21:17
i like this picture
workshop cam at 21:17
maybe .. also .. bring[ing] two domestic situations into separation / association
..because it is from Sukanta's home .. maybe some ideas of [co]habitation and even commons ..
..
dawn at 21:25
someone said about webcams: spatial anchors in a placeless sea
..
Roy at 21:26
this place of the holes can exist[s] in the separation and also in the association. it's a hole in both and it lets the common happen, in both. it's a kind of topology ?
Mort Drew at 21:27
This has been very engaging listening/reading/discussing but I have to head to bed now. See you tomorrow!
workshop cam at 21:28
topology works for me - good night,
Mort
dawn at 21:28
night Mort
Roy at 21:28
have a good night Mort
RL Wilson at 21:31

Mine up now for a bit (until 23:00 CET) <https://locusonus.org/soundmap/051/>
workshop cam at 21:31
Hi Bob
Is your stream from near your home?
..
RL Wilson at 21:35
Yes! I live 30 feet from the sea (at high tide). It's on the estuary. Spent the last 2 hours adjusting so i can have it running the rest of the week. But tonight is calm (no rain)
..
workshop cam at 21:47
.. i think in Kolkata we are no[w] really in the night, like things have handed over to night -
..
workshop cam at 21:58
.. what is that?!
dawn at 22:01
.. sounds like smaller birds might be waking up already
..
dawn at 22:09
i was wondering about the domestic in relation to something like the walney feed, or perhaps queensland
workshop cam at 22:11
so the domus is turned inside out.. infiltrated?
dawn at 22:12
i'm not sure ..
dawn at 22:20
.. someone recommended 'the book of disquiet' .. in relation to overhearing yourself on a stream from your house

-hearing yourself with delay
..
dawn at 22:22
hearing yourself as you were maybe not recognising it..
or only partially
maybe also catching something that just left
that owl like dog howl again
workshop cam at 22:27
i feel like, topologically, once you are trying to imagine what it is that has left a trace, you are also equally on the verge of thinking, what else is out there - not just forensically, in the past, but now or in a future now
i guess that uncertainty seems important - hence also the not recording
dawn at 22:28
thinking of those train cam feeds, the anticipation
workshop cam at 22:29
ah yes - good example
an aura of something that is maybe happening
you know that [Fred M]oten saying: i want to be in the world because i believe there is another world in the world and i want to be in that
dawn at 22:31
idk that one but i like the optimism
workshop cam at 22:31
or [Giorgio A]gamben's idea of the coming community - as something that is not, actually, in the future, but already present but kind of awaiting perception or declaration
dawn at 22:32
i can do even less reading now -

hampered by lockdown squinting on macbook air
workshop cam at 22:32
pole sana - it s been hard on the eyes - also the back
what is that sound - the ringing? which is often [] heard
trains?
distant trains?
dawn at 22:34
i thought trains yes
workshop cam at 22:34
definitely picking up - i think we should get some rest though
dawn at 22:35
yes probably
..
that beeping..
workshop cam at 22:37
it does seem to have entered that phase of approach
in the last minutes
perhaps - of coming towards - there was that long metallic section and now kind of cardboard section
revolutionary klaxons
dawn at 22:39
dogs imminently getting r[u]n over by a long train
workshop cam at 22:40
i almost never listen on speakers - it is pretty nice
dawn at 22:40
jesus
workshop cam at 22:40
!
dawn at 22:47
i wonder how feasible it would be to have a concert type scenario where people listen to a stream like this

for 3hrs
workshop cam at 22:48
yes
Duriye at 22:50
I like the idea of concert like approach..
workshop cam at 22:50
let s do it
..
dawn at 22:55
i assume that's a person creeping around on the roof
but that would be strange behaviour
..
dawn at 22:59
probs should enforce curfew

Microphone Building

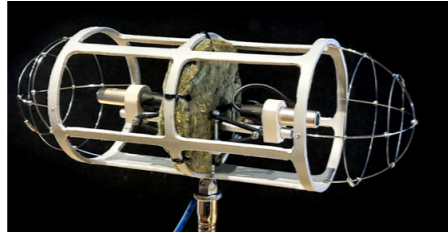

10:22 CET
'When building wind protection for microphones, the frame sounds must also be isolated, especially in quiet environments (like here in Finland). Although the EM172 is not sensitive to handling noise, the rumbling of the wind can enter the microphone via frame, e.g. vibration noise from stand et.c. The picture shows a frame for a stereo pair of microphones. The microphones are elastically attached with rubber loops (hair loops). A fur fabric covers the frame.'

Tips for soldering:

1 – When soldering smaller microphone capsules such as Panasonic WM61 or similar (5 mm), it is a good idea to use a cooler. The film of the capsule is sensitive to heat, so be careful. New lead-free tins require a higher temperature to melt. The radiator can be built, for example, from a split aluminium tube. A drill stop can be used as a tensioner.

2 – I don't know if it came to be mentioned, but when you do soldering for outdoor use, the solder flux needs to be cleaned off. The flux can be corrosive in humid conditions. A suitable solvent is, for example, isopropanol. After cleaning, varnish on the solder.

Pekka Matilainen

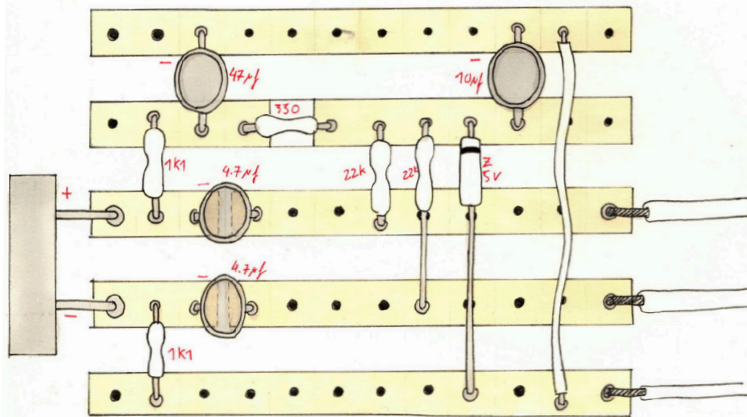

'Today we will assemble a microphone board on a piece of perfboard.'



10:30 CET
Equipment check:
Fell Communications capsules, cables,

Simple P48, from Yahoo mic-builders group:
<https://groups.io/g/MicBuilders>



Resistors



Tools



Removing the cable's rubber outer – avoid damaging the inner sheath

'I ordered the Mogami 2697 balanced miniature cable. @FEL Communications. nice and light – around 2,5mm in thickness' – Brane Zorman

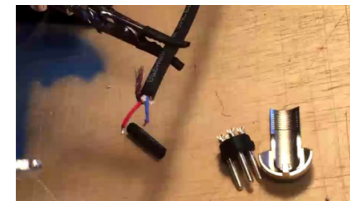

Tinning the iron, wires

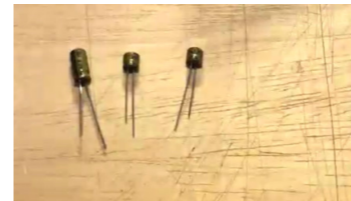

4.7uF capacitors

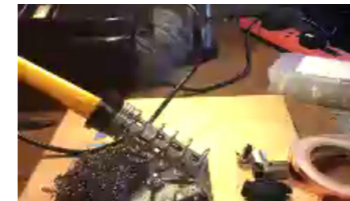

Soldering iron (30w)

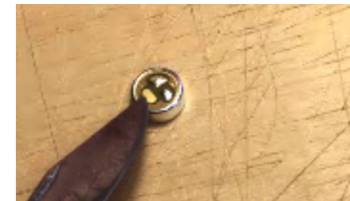

Abrade the capsule pad for easier soldering

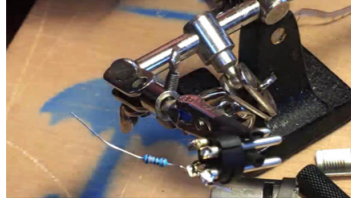

Adapted from:
<https://tombenedict.wordpress.com/2016/03/05/diy-microphone-em172-capsule-and-xlr-plug/>

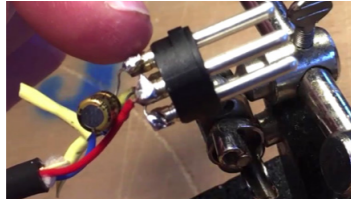
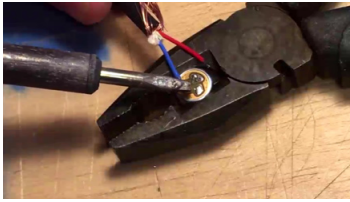
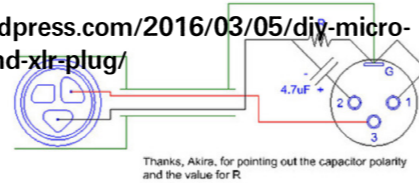

https://caperteebirder.com/?page_id=274

Q: You have two capsules but it's still a mono signal?
 A: Yes
 Q: Did you heat shrink over the wires fully first, then apply the copper over the heat shrink?
 A: Yes

The Swissonic soundcard which Grégoire identified is the UA-2X2. Brane also reports that it works well and sounds good. Some people (eg Dustin Perdue) like the Behringer soundcard which is called U-Phoria UMC202HD. To my ears it is a little bassy and unclear, but Dustin prefers it and the stream he has run in Queens is very vivid and spatial.



11:28 CET
 Heat-wrapped

Applying liquid tape to prevent short-circuit

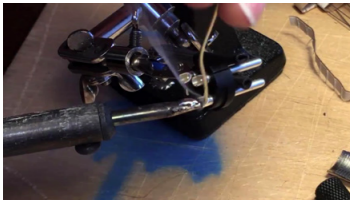

I really like atm the Native Instruments Complete Audio 2 Grégoire's mic design, using his custom PCB, is a more refined approach.

<https://micbooster.com/>

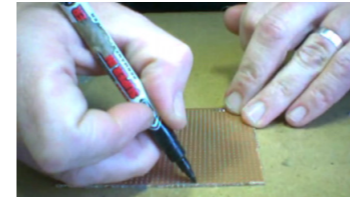

LocusCast



Micro USB to mini USB cable male to male

Pipe sounds

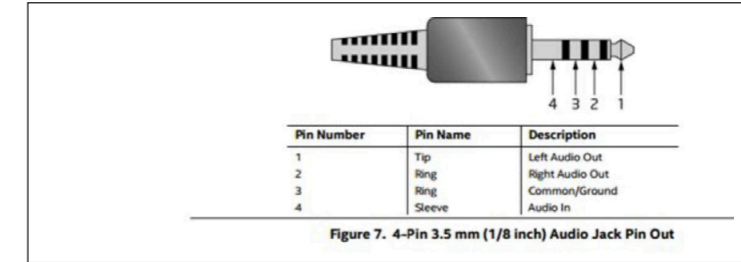

12:10 CET

The latest (pin 4) pin is commonly used for audio in, but in that case your phone will deliver the needed bias voltage

(screenshots from sound map)

<https://www.instructables.com/Connect-Zoom-H1-to-Android/>

you can download the list of currently online streams here: <https://locusonus.org/soundmap/list?out=m3u>

WHEN I'M WORKING SO IT'S LIKE FOG FOR ME SO I WILL JUST HEAR YOU AND TRY TO MAKE SOME STUFF WITH THAT
JUST UNDERSTAND SO YOU'RE INTERESTED IN USING THE SOUNDS FROM THE SERVER WHILE YOU WRITE IT SOUNDS OF DIFFERENT LOCATIONS

HAVE OR DEVICES THAT YOU CAN CONNECT ON IT TO IT IT'S REALLY VERY VERY SENSITIVE SO OVER THE YEARS AND WITH EXPERIENCE I'VE DECIDED TO LIMIT THE DIFFERENT LIKE THE CONNECTION JOINTS IN THE SIGNAL CHAIN SO TO MAKE IT MORE AND MORE

MUCH THANKS FOR THAT SO BASICALLY I'M BACK I BROUGHT ALL MY LITTLE THING IS THAT I USED TO SHARE SHARE MY CAMERA AS YOU CAN UNDERSTAND ANYTHING THAT HAS TO DO WITH MOBILE STREAMING IT'S ALL ABOUT CONNECTIVITY AND ACTUALLY AS DISCUSSING

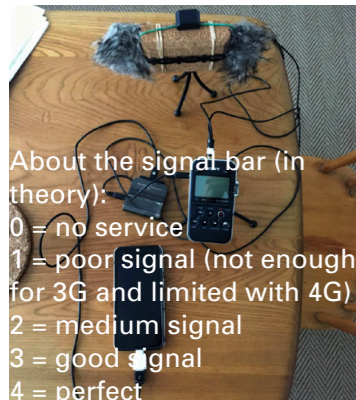
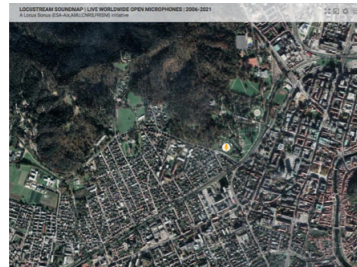

About the signal bar (in theory):
0 = no service
1 = poor signal (not enough for 3G and limited with 4G)
2 = medium signal
3 = good signal
4 = perfect

YOU WILL YOU IT'S VERY POSSIBLE THAT YOU WILL PICK IT UP DEPENDING ON YOUR LOCATION THE NETWORK ITSELF YOU KNOW YOU HAVE TO BASICALLY BE AWARE OF IT IF SOMEBODY SENDING YOU A TEXT MESSAGE ON YOUR PHONE THAT WILL ALSO BE HEARD IT WILL BE

Pure Data

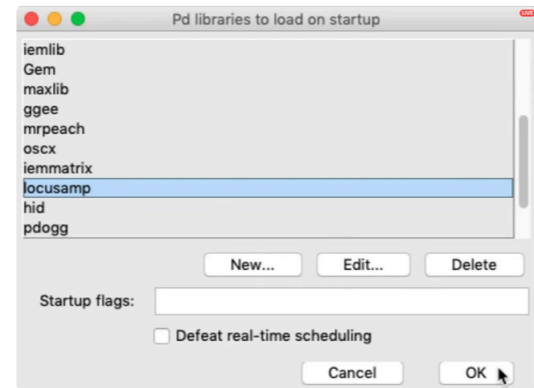
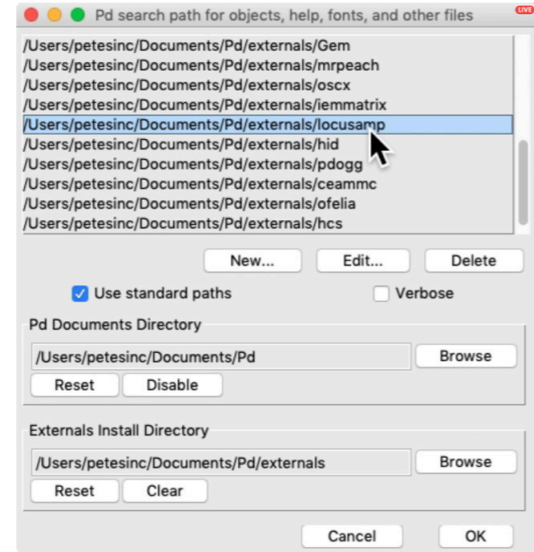

USE THIS PATCH TO MIX AND SPATIALISE 2 OR MORE MICROPHONE STREAMS WITH LOCUSCAST.

To use the object locusamp- download the external library here : <https://locusonus.org/pd/> and include the folder in pd's search patch and startup. This patch also requires externals from the following collections : ggee, cyclone, ceamc.

This part grabs the list of stream URLs that are CURRENTLY available on the soundmap - you may need to install the shell object.

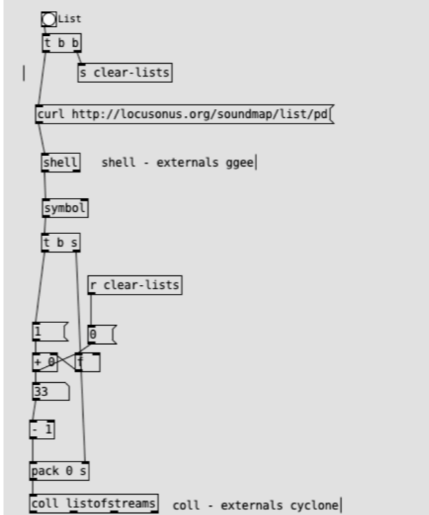

click on the coll object to show list of contents (streams)

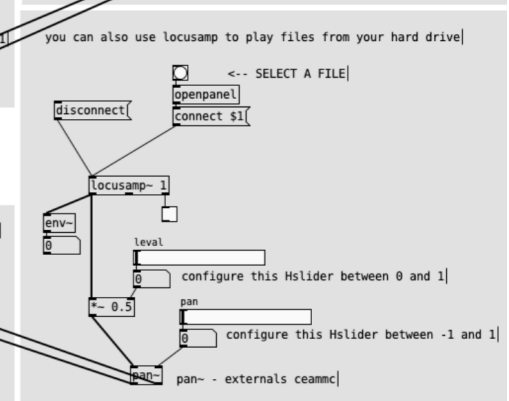
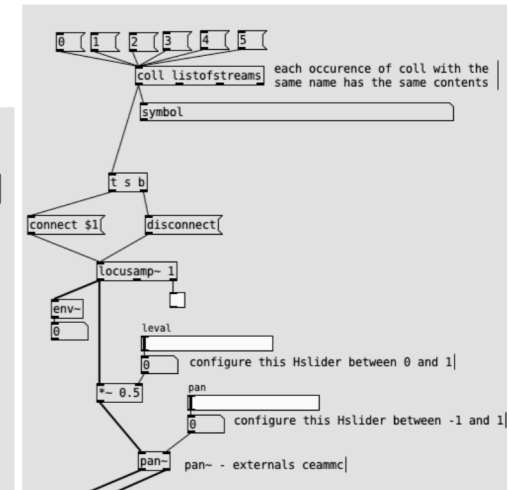
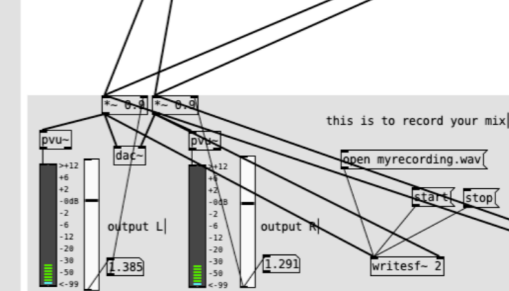
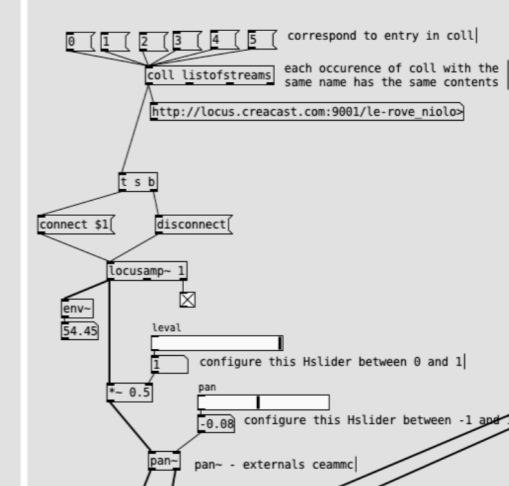

mp3;http://mp3s.nc.u-tokyo.ac.jp/OTSUCHI_CyberForest.mp3;http://2.onj.me/outside;http://locus.creacast.com:9001/ravenglass_the_estuary.ogg;http://locus.creacast.com:9001/kolkata_chittaranjan_colony.mp3;http://locus.creacast.com:9001/south_walney.mp3;http://locus.creacast.com:9001/aix-en-provence_arabicus_sonus.ogg;http://locus.creacast.com:9001/rainforest_canopy_mary_cairncross_scenic_reserve.mp3;http://planktone.ddns.net:2500/planktuin;http://locus.creacast.com:9001/deptford_albany.mp3;http://locus.creacast.com:9001/florence_ears_in_space.mp3;http://locus.creacast.com:9001/acra_wave_farm.mp3;http://locus.creacast.com:9001/ljubljana_steklenik.ogg;http://locus.creacast.com:9001/marseille_frioul.mp3;http://locus.creacast.com:9001/mobile_cumbriamobile.ogg;http://locus.creacast.com:9001/prague_komorany.mp3;http://locus.creacast.com:9001/vancouver_thebluecabin.mp3

being out in the estuary at night - very little in the way of foreground or landmarks to navigate by
RL Wilson at 9:39 PM
exactly that
RL Wilson at 9:40 PM
there's 'nothing' there. that's why we can hear the sea so far away so well
Grant at 9:41 PM
ah yes - so it is actually to do with the topography, not just the way the equipment is arranged - i remember a night walk by the sea just like Glenn describes
dawn at 9:42 PM
night and not day
Glenn Boulter at 9:42 PM
also, the way the tide comes into the estuary is very indirect and multidirectional - it kind of creeps up from all sides through channels and streams rather than advancing in an orderly line
dawn at 9:44 PM
somehow it is dark
Grant at 9:44 PM
also in some ways i guess the surf is a kind of lag effect of wind that created the swell and then fell still
RL Wilson at 9:47 PM
tonight is a real contrast. very quiet.
Glenn Boulter at 9:49 PM
Quite busy with birds now compared to when we first started listening
Grant at 9:50 PM
Is it the tide bringing them closer
We were thinking to play this in the

'domestic' set
It feels like it has something specific - Maria was using the term 'intimacy' - as a home
RL Wilson at 9:54 PM
will it help if i go and say hello near the mic?

[Close: 10:16 UTC 0]

Day 3

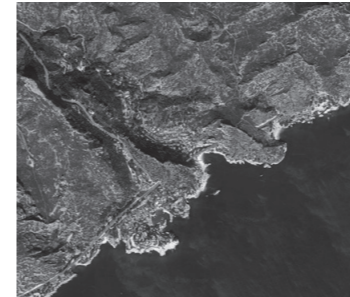

Streambox Building

Today's morning session looking at off-grid streamboxes starts at 10:30

10:52 CET

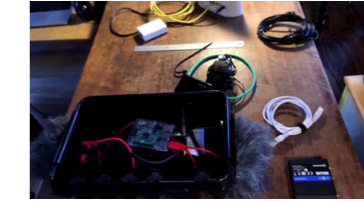

Off-grid streambox setup

Stream demo: http://locus.creacast.com:9001/stream_demo.mp3

Requires a Pi with an Ethernet connection

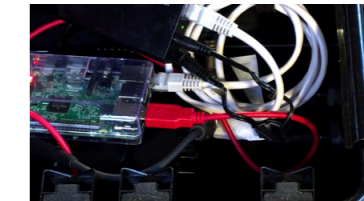

Recording by Leah Barclay of a possum sleeping on a streambox ([link](#))

Q: Grant how did you get from the POE 48v down to 5v for the Pi?

A: (check answer)

Q: When running the ethernet set up in your garden, do you permanently have a window open to pass the cable through?

A: I drilled a hole in the frame of the window, just big enough for the cable to pass through

UK solar – 30 degrees south

Ethernet connects from solar to streambox. XLR cables connect to the microphone

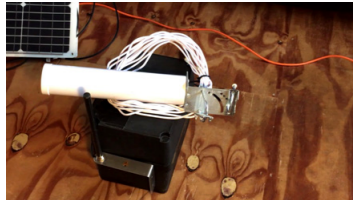

The panels charge pretty well in low-light, but you'll need more panels for UK streaming: 200w (see Martin Scaiff – ReCast Education).

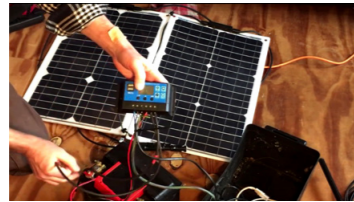
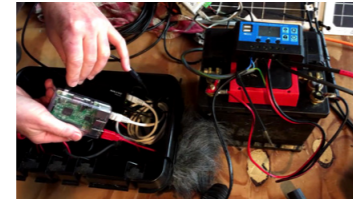
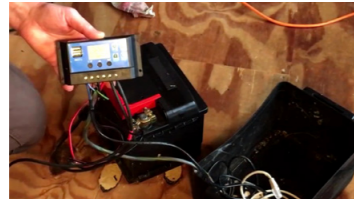

Small battery good for transportation by horse.

11:25 CET
I like a semi-flexible (bendable) solar panel.

Positive / negative cables marked with red heat-shrink.

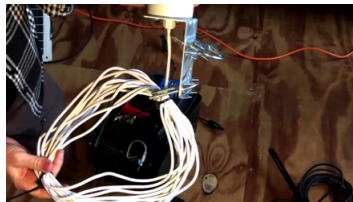

Spaghetti

Q: Any tips for extreme weather conditions? it's very dry (sand-dunes) where i aim to put mine but gets a lot of rain and in winter below freezing
A: Cyberforest have a

long-term installation in Hokaido which gets many feet of snow. This setup does ok.

12:00 CET
Q: When working with solar pannels and public spaces – do you take any precautions when thinking about people possibly nicking or messing with the set up? Or is that not a concern in the rual spaces you've set up in so far?
A: In Cerro Pelón, we picked an off-the-beaten-track location. Roofs are also good.



Finding an alternative for the discontinued _____ (?)
– Pi 3 + PiSound (£100)

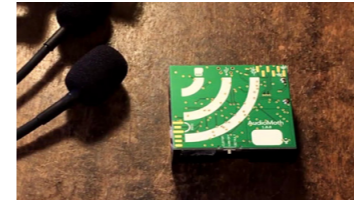
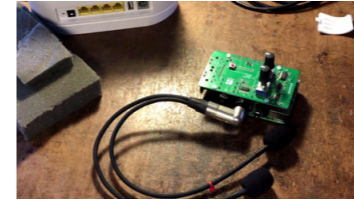

or AudioMoth:
<https://www.openacousticdevices.info/>



or IQ (in production).

14:31 CET

Now I have figured out how to build the system. I start with a Cirrus Logic hat and amplify the signal to the maximum. I put the microphones under the eaves right on the wall, this way I get an additional gain of 6 dB. Once the system is up and running, there is time to reassemble its components. The 6 dB (compared to the level of the free field) gain comes when the microphone is completely attached to the surface, a kind of pressure effect - on the surface the air particles cannot move back and forth, thus increasing the pressure by 6 dB.
– Pekka Matilainen

<https://solo-system.github.io/home.html>

LocusCast

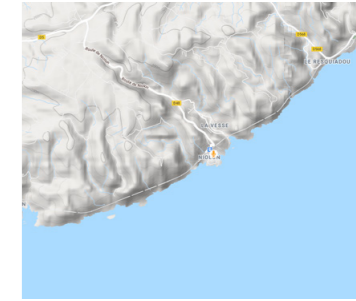

11:45 CET

Here is our workshop by the sea! Today we're fishing some sounds in the Calanque de Marseille. We will post some documentation during the day.

We're also using a DIY binaural microphone.



14:24 CET

From Niolon, France, we will try to make a video sharing of the installation of Peter's microphone in the Locuscast vocal channel.

You will also be able to listen to a stream on the map commented by Catherine.

14:56 CET

The locus Sonus boat is named 'Ni Dieu Ni Maître' We streaming on the boat right now but we will try to going out to listening properly the microphone.

creaking boat sounds

You can hear in direct time the stream under the boat with these address on locus map: https://locus.creacast.com:9443/le-rove_niolon.mp3

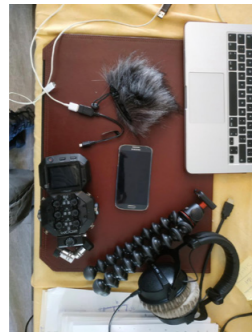

14:22 CET

Hello to everyone, I am ready to start streaming on the locuscast map in a few minutes! From Crete, Palaikastro Wetland...



Microphone Building



17:13 CET

Re: earlier discussion of streambox performance in the cold - here's my streambox just now, which has partially melted through its snow covering. The outside temperature is right around 0 C.

I've just read the specs of the new iq audio card from raspberry pi and it states that it is mono (mic 2) but there is an option to fit an additional mono Mic 1. Sounds the same as the

- original board
 Codec Zero features:
- High performance 24-bit audio codec
 - Supports common audio sample rates between 8-96kHz
 - Built in MEMS microphone (Mic2)
 - Mono Electret microphone (Mic2 left)
 - Automatic MEMS disabling on Mic2 insert detect
 - Supports additional (no fit) Mono Electret microphone (Mic1 right)
 - Stereo auxiliary input channel (AUX IN) - PHONO/ RCA connectors
 - Stereo auxiliary output channel (Headphone / AUX OUT) - 3.5mm Stereo jack
 - Flexible analog and digital mixing paths
 - DSP for ALC (Automatic Level Control)
 - 5-band EQ (Equalisation)
 - Mono line-out / mini speaker driver: 1.2W @ 5V, THD<10%, R=8Ωç

Listening Session

Glenn Boulter01/27/2021
 Tonight's listening session is starting now - we are listening at the same link as yesterday: http://locus.creacast.com:9001/acoustic_commons_workshop_2. Starting with the new stream from @Peter Sinclair's boat in Niolon.
 PekkaMatilainen at 7:11 PM
 Is that creaking sound coming from boat fender against the dock?
 ..
 Glenn Boulter at 7:24 PM
 There's a huge range of creaks and bumps going on here, seem to have increased since we started listening
 Grant at 7:26 PM
 ha!
 i was thinking maybe the boat is at a mooring in the bay and we are hearing ropes against the timber..
 SteliosGiannoulakis at 7:28 PM
 how far are the mics from each other? stereo image is very nice by the way, at the moment I am mixing it with mine (http://locus.creacast.com:9001/@athina_athens_center) 6th floor over central Athens, distant traffic - completely different sound perspective) and it is weirdly complementary. Some interesting foreground-background dynamics
 Grant at 7:34 PM
 various modes of transport
 ..
 Roy at 7:39 PM
 it cuts each nine sec, on your side too?
 Grant at 7:39 PM

nice - thank you - i look forward to listening later
 for me there are pops - think not regular?
 not really cut-outs perhaps
 PekkaMatilainen at 7:40 PM
 Pops are water drops
 Grant at 7:40 PM
 'artefacts of transmission'
 Roy at 7:40 PM
 it seems to be ok now, but i need to play again and again
 yep
 Grant at 7:41 PM
 ah really? i thought it was a digital thing..
 PekkaMatilainen at 7:41 PM
 'Water drips from the eaves near the microphone.'
 Roy at 7:41 PM
 Just now it was 1min 3sec and i need to press play, maybe it's my technical stuff
 Grant at 7:41 PM
 hmm let me know - the pops are on the source feed, not on the relay - i checked
 if somebody wants to double check the niolon feed on a different machine, network, etc to be sure.. but perhaps they are part of it
 Roy at 7:45 PM
 again it stopped 1min32sec, i'll try
 PekkaMatilainen at 7:47 PM
 Sounds like water is getting in, maybe the boat is sinking? But there is some drop outs.
 Grant at 7:48 PM
 hmm - i am monitoring the acoustic commons workshop 2 stream and

for me the dropouts are v rare - like just then - but there are frequent small pops - for me it s not troubling but i will check again - give me a moment
PekkaMatilainen at 7:48 PM
I have 400 MB connection, stream is coming fine.
SteliosGiannoulakis at 7:49 PM
for me too is fine, nothing seems wrong
Roy at 7:50 PM
ok, maybe it's my machine, thanks
Grant at 7:52 PM
i checked again on another machine - the pops are def artefacts in the stream - @Roy I suspect the dropouts are your end..
it s such a vivid stream - i think the odd pop can only add to it
PekkaMatilainen at 7:53 PM
pretty many listeners, the buffer here is only two seconds
Grant at 7:53 PM
the way it goes quiet for passages.. when the water becomes stiller.. like the energy withdraws from the system..
Roy at 7:54 PM
it's seems ok now and it's amazing, space and slow little sounds
Grant at 7:54 PM
kind of organic and machinic at the same time
Roy at 7:54 PM
thanks
Grant at 7:54 PM
np
it s like the timber is also the sensor even the liquid, when you hear it,

sounds like it s filtered through fibres
PekkaMatilainen at 7:57 PM
some dropout happens time to time
Grant at 7:58 PM
i feel like the pops reveal that extra layer of transmission - like the self-noise of the whole assemblage is opened out
Roy at 7:59 PM
it seems it's an effort and very soft in the same time, like a very deep research time, niolon's stream maybe is listening itself ?
Grant at 8:00 PM
it is!
its the sound of sound
PekkaMatilainen at 8:00 PM
The sound is similar to being in a building by the water. To my recollection, I have a recording of the beach sauna where the waves on the lake did sounded like that.
Roy at 8:00 PM
it's perfect, like ascoltando, listening of listening
SteliosGiannoulakis at 8:01 PM
those wet blibs!! and the odd digital click
Grant at 8:02 PM
yeah! like visceral digital
PekkaMatilainen at 8:02 PM
yes, like too much moisture on the capsule
Grant at 8:03 PM
i agree - something about the way aqueous sounds are transposed through the structure
actually i remember a building that was built from reclaimed shipping

timbers
'ribs'
PekkaMatilainen at 8:06 PM
I had a shotgun microphone, the capsule was broken, it made similar clicks.
Mike Bullock at 8:07 PM
Condensation inside a capsule can make it click and pop. Sometimes all that is needed is to take it apart and put it in front of a fan, or just let it sit and dry out
PekkaMatilainen at 8:08 PM
But these clics are in the middle of stereo image, so it's not capsule, both can not click at the same time...
listening again....
Mike Bullock at 8:09 PM
good point
PekkaMatilainen at 8:10 PM
Something wrong with the powering of mics
dawn at 8:13 PM
can hear you typing glenn
Glenn Boulter at 8:13 PM
sorry Dawn!
dawn at 8:13 PM
subtle intervention
no worries
PekkaMatilainen at 8:20 PM
Is there someone in the boat?
Sounds like steps?
ludovic landolt at 8:21 PM
@Peter Sinclair ?
PekkaMatilainen at 8:24 PM
It's getting spooky :scream:
ludovic landolt at 8:34 PM
ja a bit !
Grant at 8:41 PM
we were planning to go to Frioul

but the stream is quite unstable at the moment
dawn at 8:53 PM
reminds of Meredith Monk's Hocket tense and soothing at the same time
SteliosGiannoulakis at 9:10 PM
has anyone checked my stream?
how does it sound
Grant at 9:10 PM
i was listening - it was sounding good!
PekkaMatilainen at 9:12 PM
Sandman calls, see you tomorrow
:dizzy_face:
Grant at 9:12 PM
we were wondering if we might include it with another stream, from Crete, in the listening program tomoro or friday
g n @PekkaMatilainen
yantantethra at 9:12 PM
Good night Pekka.
SteliosGiannoulakis at 9:13 PM
ok
Grant at 9:14 PM
let me double check: is your stream athina centre - i could have got this wrong
SteliosGiannoulakis at 9:14 PM
yes it is
Grant at 9:14 PM
ah good
yantantethra at 9:16 PM
Thanks @dawn - I've just listened to the stream together with a live version of Monk's Hocket. Once balanced it was a rather lovely experience. Tense and calm at the same time. :slight_smile:
dawn at 9:18 PM

something to do with the rocking
Grant at 9:19 PM
for sure - give us a little time to confirm the program tomorrow, and we will check with you
SteliosGiannoulakis at 9:19 PM
nice, let me know so I make sure it is on
Grant at 9:19 PM
that was meant to be a reply
yantantethra at 9:20 PM
Yes, but also not being able to quite determine the sequence of events/ changes.
SteliosGiannoulakis at 9:20 PM
yes i deleted and reposted the message, sorry
Grant at 9:21 PM
np!
when you hear the water, you sense that there is no ground
the bottom kind of drops out so maybe then you sense there is something strenuous but at the same time buoyant
dawn at 9:22 PM
the suspense already suggests no ground to me
Grant at 9:22 PM
about remaining afloat
dawn at 9:22 PM
something trussed up
Grant at 9:23 PM
ah yes
yantantethra at 9:23 PM
This is the most wonderful stream and has made me think about other small/enclosed spaces we could stream. BUT I'm getting tired so will leave you to the rocking and creak-

ing. Sounds like the wind is getting up! See you in the morning.
Grant at 9:23 PM
hm although also perhaps with lift
SteliosGiannoulakis at 9:24 PM
also the hydrophones give no ambience, so it is weird and wonderful
dawn at 9:24 PM
night andrew
SteliosGiannoulakis at 9:24 PM
good night
Grant at 9:24 PM
like the opening to andrei rublev - with the ropes of the balloon..?
good night good night
Josephine at 9:24 PM
I'm really loving this stream too
Glenn Boulter at 9:26 PM
Good comparison, that's all I can hear now!
Grant at 9:27 PM
it kind of inverts the whole thing..
Roy at 9:41 PM
gn all
Grant at 9:45 PM
gn Roy
Grant at 10:00 PM
I have some things to do but happy to leave the stream running if ppl are still listening?
Mike Bullock at 10:01 PM
I just tuned into Stelios' stream actually
Grant at 10:01 PM
or, we could take 10pm london time as a stopping point. Of course you can continue to listen to the stream directly on the soundmap or the server
dawn at 10:01 PM

https://locus.creacast.com:9443/le-rove_niolon.mp3
think a curfew might be good
feeling a little dizzy
Mike Bullock at 10:02 PM
that's fine
Grant at 10:03 PM
Ha ok let s do that then
Good night - see you tomorrow i hope
SteliosGiannoulakis at 10:03 PM
gn!
dawn at 10:03 PM
gn
Mike Bullock at 10:03 PM
gnite!
Alangus at 10:06 PM
Thanks, another lovley evening listening.
Josephine at 10:10 PM
Thank you and goodnight, it's been wonderful

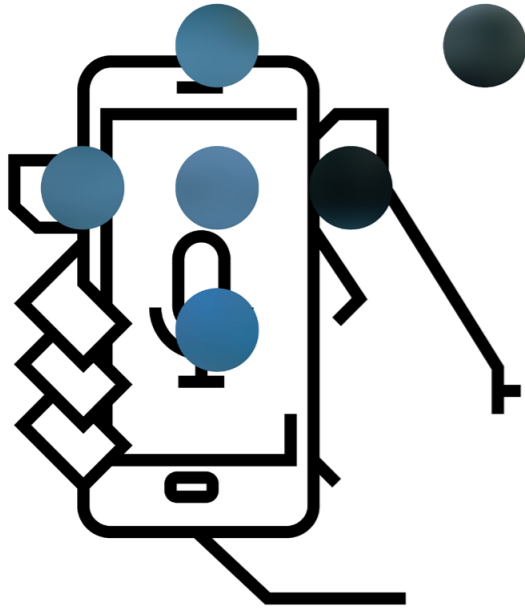

http://locus.creacast.com:9001/acoustic_commons_workshop_2

10:01 CET

Hello all, this is a quick update for Thursday 26th. Today will be a more self-directed day for people to develop work amongst themselves or in collaboration. The session leaders will be available on the Discord channels at different points to support this.

If you are working on a project or stream this week, please let us know by listing it in this table (this is also a good way to find possible collaborators): <https://docs.google.com/spreadsheets/d/1YUZxxUHeWr5v0yGB6ot-U7X-pALVcy0skeJy7L0-v1b0/edit#gid=0>

Please also let us know in the table if there are things you'd hoped to find out about and haven't yet, so that we can try and arrange a session or discussion to fill the gap.

We are planning to run informal sharing sessions on Friday afternoon and will use the table to give us a sense of what people are working on.

We'll also be running listening sessions from 19:00 CET again each evening in the #listen-chat channel for anyone that wants to drop in.

11:21 CET

Tonight at 20:00 CET we'll be streaming a program from CONA in Ljubljana, followed from 21:00 CET by streams from Greece on the LS Soundmap. You can listen at the link [left] and share responses in the salon textuel: 'listen-chat'

CTW Project Sheet

Name + Contact	Organisation	Project / Stream Details
Diarmuid Drew		A streambox running in my garden recording the dawn and dusk noises. A raspberry pi zero with an IQ audio soundcard running off a 70Ah leisure battery, connection to my home wifi via a cantenna directional wifi antenna. Stream currently down changes in progress.
Stelios Giannoulakis	Contemporary Music Research Center (), Athens Greece	I set up a Locustream from Athens, Greece (Athina_Athens_Center) 6th floor overhearing waves of near and distant traffic - Has been live on and off since taking part in Reveil 2020
Ainolnaim Azizol	University of Bristol / Universiti Teknologi MARA Malaysia	In progress: 24h live stream natural soundscapes from mangrove forest, natural lake - hydrophone, limestone cave & turtle sanctuary Malaysia for archive/sound installation/electroacoustic composition etc. planning to use diy streambox device & locus sonus platform
Mike Bullock	Ears In Space, Massachusetts USA	Recently restarted: 24h livestream of my property to Locus Sonus soundmap, using a SoundCamp streambox; first started in Winter 2019. Future goals: Incorporate real-time bat detection hardware into livestream; off-grid livestream events in local nature reserves.
Spyros Roumeliotis	HMU	My first idea was to connect a coil directly to my mobile phone, taking advantage of the portability, to be able to stream something like electrical walks project. I connected my antenna in a 4pin mini jack and it worked. My impression was that the mobile phone was not producing and streaming exactly the quality that I expected. So I decided to use a zoomH8 as a sound card for my android and went for a walk near a wetland to transmit its sounds for a while just to test the locuscast app. My purpose was to explore the possibilities of the locuscast app and I do not have any project to present for now.

End-of-week Sharing Details	Feedback + Notes
	My blog is at https://rpisounds.wordpress.com/
The goal is to replace the current setup (Rode M5 pair, long cables from balcony into soundcard, desktop pc, BUTT) with a streambox and dedicated mics as permanent, always on, installation.	Apart from the main mode, soundscape appreciation deep listening etc, which I totally get and enjoy, I would be interested to explore other creative, maybe performative, possibilities around streams. These could be for example stream mixing, microphone manipulation - dynamic micro sound exploration, electroacoustic improvisation in response to a stream, and other. Have done some experiments. It would be nice to discuss this further if anyone else might be interested, for valuable insight and possible collaboration http://steliosgiannoulakis.wordpress.com/

Cont.

Name + Contact	Organisation	Project / Stream Details
Jonathan Kemp	Collaboration with Locus Sonus.	
Roy	Collaboration with Locus Sonus.	I'm Roy and Esther. Under this last name, i'm making a project with Locus Sonus, in french for the moment: https://sthene.blogspot.com/ and an audio blog : https://audioblog.arteradio.com/blog/159725/pz-point-zero . It's the begining.
RL Wilson	RE Drift	Current temporary stream from Ravenglass estuary for Reveil and occasional weeks such as this. Intention to build off grid box using solar to be sited at Drigg nature reserve, Cumbria, UK.
Grégoire Lauvin	Locus Sonus	Tech woarkshop on using MEMS I2S microphone to assemble a DIY stereo soudcard for raspberry Pi Streamboxes. Documentation will be added to the microphone building salon
Shang	RCA	I am building WebXR worldwide virtual experience and I try to build a streaming system (with webaudio before) for the web-based experience. Due to a personal issue, I have no time to join the New Atlantis workshop. hope to reach out later.
Kathryn Marshall	Locus Sonus	I am a performance and video artist here in Aix-en-Provence for the Locus Sonus residency program. This week I learned to build a basic microphone with Grégoire and also did some group live-streaming from les Calanques in Marseille using the LocusCast app and we also played with some hydro-phones and other gadgets.

End-of-week Sharing Details	Feedback + Notes
	to learn what technolgies possible for 24hr livestreaming from remote areas where no cell/internet bandwidth and importantly no line-of-sight antennae permitted
I'll choose a place outside this afternoon (28th) and I would try to listen to several streams at the same time, including that of the landscape, with the headphone filter and produce one. Translate that into voice, writing and drawing, during three hours this afternoon. I have an iphone with locuscast, two computers, a loudspeaker and a zoom H2.	I don't have the materials to build what i would like to do, it will be for the next ACC workshop i hope. if this idea create some interesting things, i would like to be autonomous from battery to wifi.
	These two experiments I would like to merge, learning how to make a DIY microphone that is more integrated with my body as I found it cumbersome to be holding my phone with the Zoom attachment that I was afraid of dropping as I hopped over rocks and into estuaries, etc. I'd like to learn more about microphone mechanics to see how and where I can push their limits for eventual live performances. Another problem I'd like to solve is being able to hear what I am recording as I am streaming it. Live-streaming without any notion of what sound was being broadcasted (my phone cannot record, cast, and playback) was an underwhelming and isolating experience. I am also very interested in electroacoustic improvisation and playing with stream mixing, mic manipulation and also finding ways to merge external sounds (from the environment) with internal sounds (from the body). Looking for a collaborator(s) for this afternoon and tomorrow! www.vimeo.com/kathrynmarshall

Cont.

Name + Contact	Organisation	Project / Stream Details
Claudia Martinho	Rural Vivo, Gerês biosphere reserve, Portugal Audire project, University of Minho, PT	“I’m new in streaming. Project: stream of location multi-track audio in the forest reserve. Now: this week I’ve tested a Locustream (on and off) using my phone, for sound walking, near/in the forest, by water streams. In progress (need adaptors, only arriving next week): Locustream connecting phone + sound devices mix-pre 6 II recorder + binaural mics, contact mics, hydrophones, biofeedback, for live stream mixing / performances / installations / workshops. Future: to set up a permanent off grid stream box here in Gerês biosphere reserve.”
Ludovic Landolt	Locus Sonus / collective studio in Paris	I’m a visual artist interested in listening experiences. I’m a bit of a newbie with streaming but I will experiment on Friday 29th, in the locus sonus lab, with a modular synthesiser and the streaming potential of the soundmap.
Thomas Evdokimoff	The Blue Cabin, Vancouver BC	I am maintaining the live stream from the Blue Cabin through Mar 05 in support of the current artist in residence. Its been running since Monday
Lisa Hall	independent / CRiSAP	I aim to set up a static long term stream from London, currently Hammer-smith, London. My interest is in urban sound and listening. Ideally I will find a way to move this to a moving but fixed urban source at some point in the future. But step 1 is to get a streambox up and working.
Grant Smith	Soundcamp	Working on: – Long term stream with interpretation at Stave Hill Ecological Park, S London; – Long term off-grid stream on a biodiverse / heavily contaminated site on the Thames estuary in Barking, E London; – Affordable, good, small device with IQ Audio Zero and its descendants; – Contexts and collaborative networks for live streaming (all within the frame of AC)”

End-of-week Sharing Details	Feedback + Notes
	“I could only take part in some bits of the workshops, all very helpful to get a clear idea on the streaming possibilities and creative potentials. Thanks a lot. Unfortunately this week I’m busy with work and family. I’m open though to future collaborations. And I’ll get in contact with you when I get funding to set up a permanent off grid stream box in the reserve.” https://claudiamartinho.net/symbiosis-and-geometries/
	I will be very happy to exchange listening experiences especially deep listening and the aesthetic experience of the sounds of bells. Please feel free to ask me about collaboration. ludoviclandolt.com
	I underestimated the challenges of timezone difference in attending live, but am reading through the amazing info that’s been developed on discord so far. I could use some direction in developing a better understanding of the streambox software itself and how it interfaces with the server. I am reasonably comfortable with debian based linux admin but archlinux is a bit of a leap for me.
	I was hoping to learn a little about New Atlantis and how PD is being used by streamers - just an intro would be ideal to get a feel for what and how this is being used. When these sessions were happening, I was over in the streambox and locus cast groups learning about the kit.
If it fits, I could talk very briefly about the stream from my back yard in S London, which is linked to an ad hoc urban wilding project. We could listen to some rain	For me, the best outcome of the workshop would be to widen the scope of the project and stay in touch with people who’ve taken part, towards the Reveil / Soundcamp events over 1-2 May and in general. Specific thinking together and ideas from the group about best ways to be / stay in touch would be great. EG there was a discussion about whether it would be good to set up a virtual / physical workshop say once a month, where we could bring things we are working on separately or together, share, get feedback and help, etc. Does that sound feasible / like a good idea?”

Cont.

Name + Contact	Organisation	Project / Stream Details
Margarethe Maierhofer-Lischka	independent / mur.at association for net & media art	I am a musician and radio artist, working & experimenting with different technologies that expand and explore listening. I took part in the workshop on-and-off to learn more about DIY streaming and explore different tools. (Dropping in and out a lot during this week because of day work) Currently I am part of mur.at , a platform for media / net art & open source technology based in Graz, AT, where I develop and carry out art & education projects. I am also working as researcher in music & media art.
Brane Zorman	CONA, Ljubljana	Stoš and I reassembled a new housing and reinstalled software on RPI-4, ***we finished building the first working streambox this week, ***started on external housing design to install streambox, considering various materials like roof cover to absorb rainy drops, resist heavy stormy winds etc, ***started talk with NGO organisation where box will be temporary installed in about two weeks time (til mid-February), ***started to build the second unit (unfortunately pcbs and capsules did not arrive from France) ***planning to create a virtual Steklenik gallery – 8 ch sound gallery inside New Atlantis.
Ludmila Postel	Locus Sonus	I shared experiences of using streams in the New Atlantis 3D world to build some sound walks.
Pekka Matilainen	Freelancer	Working on Humisevat Kunnaat (Humming Hillocks) concept. It approaches acoustics, sounds of nature, soundscapes and the human sense of hearing in different ways. There is a blog, youtube, facebook and Freesound and SoundCloud channels under that concept. Now the project is to start making it in English while everything is in the beginning. I have been in acoustics for more than 30 years, mainly in the field of noise control. I started my field redring -hobby in the beginning of the 80's. The stream (at least one of them) is going to be in lisalmi, a rural area. But as time goes by, I am planning to start also mobile streams. In this regard, I am looking for better microphone amplifiers, as the countryside is very quiet here from time to time.

End-of-week Sharing Details	Feedback + Notes
I do not have a specific project up for now, but I am interested to set up a series of collaborations across countries. I do run a biweekly radio series for sound art & live soundperformance at a local radio station, Radio Helsinki - see & listen here: https://cba.fro.at/series/kopfokino	
	Would like to get more specific options to colaborate inside New Atlantis. Still a lot to brainstorm about....
I will share the Acoustic Commons we have made in New Atlantis. I can say more things about it, show a little video and share the link for the people who want to go into the world.	
Now in this workshop I am testing a Cirrus Logic sound card and primo em172 microphones. The stream comes from a plant cabinet that is outside in the frost with the doors open. There are no plants there :) Currently the place is Kuopio Finland	https://soundcloud.com/humisevat-kunnaat

Cont.

Name + Contact	Organisation	Project / Stream Details
Alice Angus	independent and www.proboscis.org.uk	Im a visual artist and work with drawing, sculpture, sometimes with technology, moving image and audio and sometimes with communities. I have wanted to work with live streaming so joined the workshop to learn more and explore. I also joined the workshop because I do a lot of sound drawing, especially to remote live feeds ATM, and I'm interested in running remote events encouraging other people to try it, it is a valuable way to engage in deep, active listening, participate in different environments - especially to live feeds where you have no idea what the environment looks like. I've been drawing some of the feeds this week.
Maria Papadomanolaki	Soundcamp	Bitter Orange Streambox located in a garden in Chania, Crete. the microphones are nested within branches which secures them a little bit from rain and wind but also you get the rustling of the leaves at times. the pi is secured in triple layers of waterproof material and nested within a plastic container. super diy set up. I have a WiFi USB Dongle Signal Booster attached to the pi. I am using this set up as a template to set up a streambox on a tree at the Flora & Fauna Preservation Park here in Chania. There is also a plan to set up a second streambox by one of the ponds in the park. This would be an offgrid installation. In addition to this, I am also using the locuscast app to perform telematic soundwalks as part of an ongoing project (a certain geography).

End-of-week Sharing Details	Feedback + Notes
	I'm wondering if the presentations and the chat will be archived to read later?
	I would like to develop an off-grid recipe to trial and install at the park. I will be in touch with the rest of the team. www.voicesoundtext.com

Microphone Building

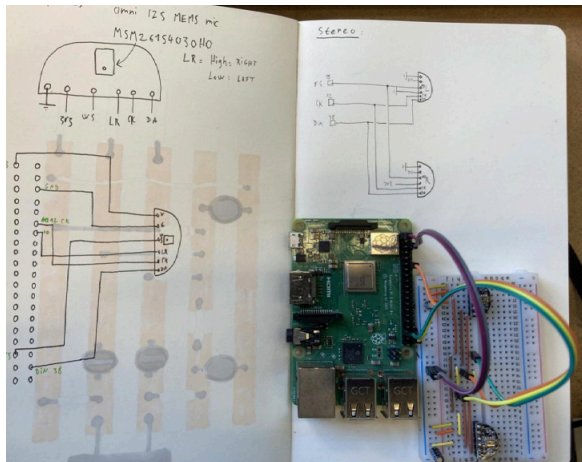

11:36 CET

The microphones on the board, ready for a test. The microphones can be identified on the I2S bus as left or right. Setting the LR pin low identifies as left, and high as right. You can use a GPIO pin for that, but on the breadboard I just hard wire this for simplicity.

For two I2S devices, you just have to wire the 3 bus line in parallel.

The I2S bus has 3 lines: a clock line, a data line and a word select line. Clock line goes on GPIO pin 12 of the Raspberry Pi, data on GPIO pin 38, and word select on GPIO 35. The microphones on the board are the MSM261S4030H0. Frequency bandwidth is quite narrow: 100Hz to 10KHz, as they are mainly for voice.

44

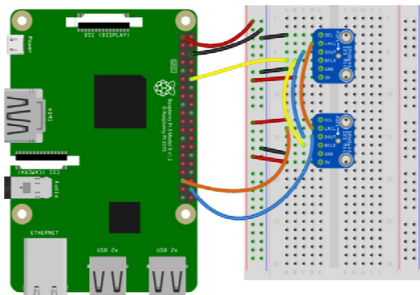

How to wire two I2S microphones on Adafruit's board: <https://blog.adafruit.com/2017/04/03/new-guide-instructions-for-adding-i2s-monostereo-audio-now-in-i2s-mems-microphone-breakout-guide-adafruitlearningsystem/>



Adafruit has a nice how-to for their own version of a MEMS I2S mic breakout board on Raspberry Pi: <https://learn.adafruit.com/adafruit-i2s-mems-microphone-breakout/raspberry-pi-wiring-and-test>

28/01/2021

15:55 CET

Using the ICS43432 MEMS microphone on a Raspberry Pi with i2s: <https://github.com/nejohnson2/rpi-i2s>

45

Pure Data

11:42 CET

This is a release of PureData distribution used in the CEAMMC (Centre for Electroacoustic Music Moscow Conservatory) and ZIL-electrostudio: <https://github.com/uliss/pure-data/releases/tag/v2020.07>

Listening Programme

28 January 2021
20:00 CET –

20:00

Introduction: Brane Zorman (CONA, Ljubljana)
Boštjan Perovšek: Interweaving Soundscapes
Manja Ristić: Sonic Ontology of Negligence
Both works were exhibited at Steklenik gallery for sound, bioacoustics and art

21:10

Live streams from Greece on the Locus Sonus Soundmap (order subject to change)
Katerina Tzedaki (HMU) – Rethymno, Crete
Stelios Giannoulakis – Athens central
Maria Papadomanolaki – Chania, Crete

Listen at: http://locus.creacast.com:9001/acoustic_commons_workshop_2

THURSDAY / JEUDI

Listening Session

Tonight's listening session starting very shortly - listen at: http://locus.creacast.com:9001/acoustic_commons_workshop_2
We'll be starting with two works presented by CONA, originally exhibited at the Steklenik gallery for sound, bioacoustics and art: Boštjan Perovšek: Interweaving Soundscapes
Manja Ristić : Sonic Ontology of Negligence
Introduced by @Brane Zorman
Stream is live now
Roy at 7:05 PM
Good sound from the mic !
SteliosGiannoulakis at 7:06 PM indeed!
Peter Sinclair at 7:16 PM :thumbsup:
Mike Bullock at 7:55 PM Beautiful
yantantethra at 7:56 PM Yes.
Duriye at 7:59 PM Very intriguing. Space, movement and keeping the tension that are captured me.
Mort Drew at 8:07 PM this is not a very nuanced observation but I feel like I'm being called to the watery depths by sea sirens
Peter Sinclair at 8:15 PM This is reminding me of those gorges Brane & Irena took us to...
Roy at 8:22 PM Mermaid are softly singing and create some sound'textile.
yantantethra at 8:24 PM lovely feedback!

Mike Bullock at 8:24 PM Bravo Manja!
yantantethra at 8:25 PM wonderful work. Bravo
Mort Drew at 8:25 PM thank you! Well done all - really compelling broadcast
Josephine at 8:25 PM That was great - a whole world in sound
Roy at 8:25 PM ludovic landolt at 8:25 PM thank you ! merci, it was wonderful
Mike Bullock at 8:26 PM Yes great program, thank you
Grant at 8:27 PM Thank you thank you
Roy at 8:27 PM Thanks a lot, it's inspiring and open for the reflexion.
Grant at 8:28 PM We are now with a live stream by Stelios Giannoulakis from Athina -- Athens central creuit at 8:30 PM link?
Mort Drew at 8:31 PM http://locus.creacast.com:9001/acoustic_commons_workshop_2
yantantethra at 8:41 PM Clear and detailed stream @Stelios-Giannoulakis with so much to listen to. Really enjoying it. :slight_smile:
Duriye at 8:43 PM I have been missing to be in Athens so it feels I am almost there with this clarity of sounds.
Grant at 8:52 PM Thank you Stelios
We re now in Rethymno, Crete

This stream is by Katerina Tzedaki
PekkaMatilainen at 8:55 PM It is good for those who work with sound when there is sound, as in Athens or Crete. Here in the north it is sometimes so quiet that you think the equipment is broken, nothing is heard. Just a moment ago I went to the balcony to check the equipment, they were fine, there was just no sound what would have been heard :slight_smile:
Is this an oil burner in the boiler room?
Grant at 8:59 PM .. in the village of Loutra
tzed at 9:01 PM it might be an oil burner, but 4 houses away... it is not really near.
PekkaMatilainen at 9:06 PM Lots of olive trees there
kathryn.marshall at 9:09 PM Been listening to the casts all evening -- has transformed my little studio into an airy (and leaky) space, at times I forgot I was listening to the cast and then my bluetooth speakers cut out and I was dumb-founded by the chasm of silence it left in its wake. Very much enjoying this chill-and-listen session, thank you so much for casting!
Grant at 9:09 PM thank you for listening
Roy at 9:11 PM It's a really strong, deep sharing.
kathryn.marshall at 9:12 PM Thank you Mike -- I really appreciate your feedback and leaving this comment :slight_smile: and what

you said about it being a collective image-generating experience is right on point. If you'd like to see that guided tour, you can see it here : <https://vimeo.com/kathrynmarshall/devantvous> (there are other guided visits and other performances on the vimeo page if curiosity strikes)
Vimeo
Kathryn Marshall
Performance of "Devant Vous," : Fausse Visite Guidée / Fake Guided at 9:16 PM
Grant at 9:17 PM As you can hear, the internet is a bit unstable in Rethymno, i think
tzed at 9:18 PM yes it is
kathryn.marshall at 9:18 PM Fine line indeed -- well stated, I couldn't agree more. Making art about art as a statement on art itself is almost like what we were discussing earlier, about feedback loops and call and response and how it can really mess with nature and the creatures living in it. (For those of you who missed our chat earlier, @RL Wilson told us a story about how his mic was recording birds outside his window at the same time his computer was casting the audio and it made the crows crow back at their crowing in an infinite loop)
Grant at 9:18 PM It would be nice to move to Chania, also in Crete of course.
But I think it's a bit more unstable there -
So we may need to listen to Maria

Papadomanolaki's stream from Chania another time
Unless of course it's a network issue here - i don't think so but it could be dawn at 9:20 PM
can we listen to Leah's at some point
Grant at 9:20 PM Would now be a good time?
Roy at 9:21 PM When listening Rethymno : https://sthene.blogspot.com/p/blog-page_77.html
pz
a form of waiting consisting of absences an apnea allows reconstitution erroneous transparencies layers irregularity of lines this ...
Mike Bullock at 9:30 PM @RL Wilson 's story reminded me - On YouTube recently I came across a video of some of Sir David Attenborough's first TV broadcasts, from 1961 - he plays a lemur's call from a big "portable" tape machine and gets distress calls from lemurs in response. At that time I don't think they realized this was not really a good thing to do casually - the idea of recording and playing sound in the wild in this way, with smaller battery powered machines, was still fairly new.
Grant at 9:44 PM thank you, Roy - very nice sparse texts
évidence of pigeons!
sleight évidence perhaps
Grant at 9:52 PM is it strenuous for dogs to bark?
Mike Bullock at 9:53 PM

I love the delay line on that dog :slight_smile:
Grant at 9:53 PM ha
Roy at 9:55 PM Grant you know my work !
Grant at 9:55 PM it s a nice link - point zero - thank you
Josephine at 9:56 PM yes I'm enjoying it too, Roy
Grant at 9:56 PM i am also enjoying the aporias .. up to a point
on balance though, @dawn and i wondered about maybe wrapping up as it comes up to 10 london time..
of course ppl can continue to listen on the server
Mike Bullock at 9:57 PM understandable!
Grant at 9:57 PM after tht
a
the drip has its own logic at one point i thought it was getting more spaced out, but it seems ongoing
but so i will say good night and thank you everybody very much for these exchanges and sounds and i will stop the stream for now..
yantantethra at 10:00 PM Good night Grant. See you tomorrow.
tzed at 10:00 PM thank you Grant!
Grant at 10:00 PM thank you Katerina of course

especially!
..
MariaP_AC at 5:59 AM Good morning all! glad to see you had a great listening session last night.
My stream was quite stable since 4pm yesterday but of course 10-12pm(GR local time) is a time where people are indoors browsing, using the network here in Greece so our connection started being flaky with signal. Add to that the fact that the pi is set up on a tree away from main house and it is relying on a very sensitive wifi connection. The stream is still up now in case you wish to listen: https://locus.creacast.com:9443/kalathas_chania_crete.ogg
I will keep it on for a couple more hours. this is a photo from Reveil set up last year.
..
Roy at 7:14 AM Very rich and nice sound, very near cat..
MariaP_AC at 7:15 AM yes it is cat mating season of course :slight_smile:
thank you!
Some photos of the tree and the set up, I took a few minutes ago, the microphones are nested within branches which secures them a little bit from rain and wind but also you get the rustling of the leaves at times.
the pi is secured in triple layers of

waterproof material and nested within a plastic container. super diy set up. I have a WiFi USB Dongle Signal Booster attached to the pi.



03:14 CET

I will leave the stream on 24h for a couple more days, I hope:
http://locus.creacast.com:9001/@athina_athens_center

And this is the blurb on my locus mic page and some links. Thank you!

The urban soundscape of Athens offers a very rich sonic experience. High density, variety, a vast array of contrasting symbols and associations. Literally, the soundtrack of our culture made up of everyday materials, devices, people, relationships, processes, and systems.

Such various elements and their inherent musicality fuel a multitude of sonic behaviors in my compositional work, and either as interrelated symbols and sonic metaphors or as contrapuntal trends and meta-images, they invite the listener to immerse into the sound and its organically connected entities. Also, besides a composer's – sound collector's maximalist kaleidoscope, city-scape informs my interest in improvisation with real-time sound design techniques.

So this is the sound from my balcony, 6th floor.

<http://steliosgiannoulakis.wordpress.com/>
<https://giannoulakis.bandcamp.com/>
<https://www.mixcloud.com/schemamusicalis>
<http://www.youtube.com/user/stgiann>
<https://soundcloud.com/stgiann>



08:15 CET

Good morning all! glad to see you had a great listening session last night.

My stream was quite stable since 4pm yesterday but of course 10-12pm(GR local time) is a time where people are indoors browsing, using the network here in Greece so our connection started being flaky with signal. Add to that the fact that the pi is set up on a tree away from main house and it is relying on a very sensitive wifi connection. The stream is still up now in case you wish to listen: https://locus.creacast.com:9443/kalathas_chania_crete.ogg

I will keep it on for a couple more hours. This is a photo from my Reveil set up last year.

The microphones are nested within branches

which secures them a little bit from rain and wind but also you get the rustling of the leaves at times. the pi is secured in triple layers of waterproof material and nested within a plastic container. super diy set up. I have a WiFi USB Dongle Signal Booster attached to the pi.



09:18 CET

Hello, this morning i'll work in cheese and wine shop, I'll stream with my iphone sounds : the name is forcalqueer. I hope hear you this afternoon. Yesterday work with little signal: https://sthene.blogspot.com/p/blog-page_89.html

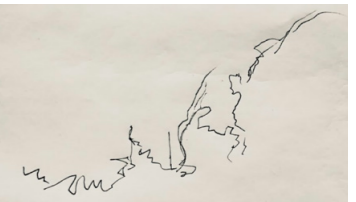

Microphone Building

10:59 CET

So, last Wednesday in Niolon, someone ask if it will be possible to use an hydrophone to stream while kayaking. We discussed using a usb soundcard on a mobile phone to use one of the PVC hydrophone, but ultimately decided to assemble a simple hydrophone using the primo in oil method and the phone jack microphone input.

We recorded the first test during a kayak ride outside of Niolon's port. It worked quite well, but with some flaws to correct. The 2 minutes I posted earlier is from this recording.

Problems are: Maybe a too long cable (3m or more) because we picked up a lot of electromagnetic noise in the harbour. At sea they disappear. Then, the microphone quickly saturates and goes silent for up to 2 seconds. Maybe adding a

resistor to adjust impedance can solve this issue. We use a photo roll plastic box filled with diesel motor oil, sealed with hot glue.)

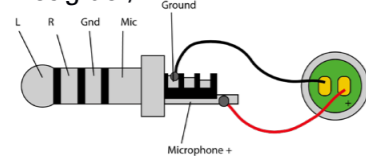

How to solder an electret microphone on a 4 ring jack to use on a mobile phone



Sharing

10:57 CET

Welcome to the final day of this week's workshops. This afternoon, we will be inviting everyone to briefly share their projects, streams and work in progress.

11:30 CET

hello people, I have been very silent this week, dropping in and out a lot because of day work going on. Yet I managed to set up my own mobile stream from Graz: http://locus.creacast.com:9001/graz_all_ear.ogg

I will do a (partly commented) evening soundwalk around the city tonight, after 20.30h

14:12 CET



29/01/2021

14:16 CET



Very nice! Mobile hydrophone prototype MEMS with streambox (Stef Cousot). Will it be possible to get some stereo separation between the MEMS mics? bcoz generally they sit close together...

14:29 CET



Stream installed on Peter Sinclair's boat - Calanque De Niolon

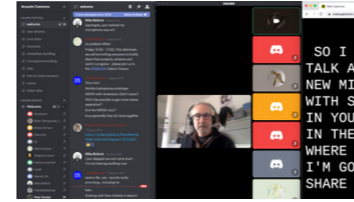

Boat streaming setup

51

The new Niolon stream is now installed on a boat in the calanque of Niolon using a WiFi extender powered by PoE. There is line of sight to the boat. The streambox is autonomous, running off a 50W solar panel feeding a 60Ah battery. In a marine battery box. The binaural head is located near the centre of the boat, feeding a Pi based streambox. All the equipment is out of the weather. Originally tried a custom mic in the keel space - next steps: additional channels.

The port at Niolon is partly exposed to the open sea. The binaural mic gives a sense of being in the cabin, hearing the sounds of the hull in closeup, with fainter marine sounds in the background.

Thank you, Peter!

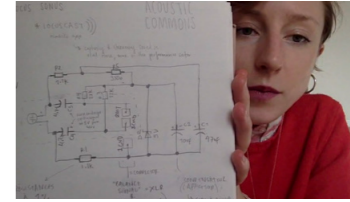

14:40 CET

Making microphones and the link to performance.

See also the Makymaky (MIT student project): <https://makeymakey.com/pages/how-to>

Wearable mics.

See also work of Hiroshi Kobayaki @ cyberforest - zooming in on micro soundworlds or parts of them.

Lag / delay as a generative element for group improvisation.

Therapeutic sonar landscapes

FRIDAY / VENDREDI



14:56 CET

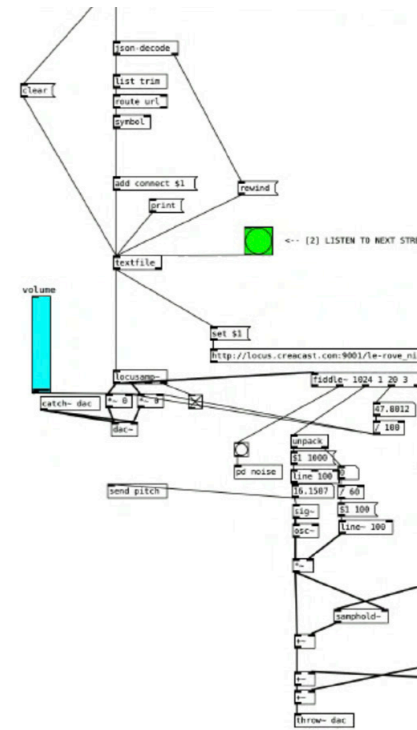

15:15 CET

My stream is up and running at the moment: http://locus.creacast.com:9001/denby_dale_sounds.mp3

My setup is a raspberry pi zero with no wifi, an external usb wifi card connected to a cantenna antenna. I've connected this to so a leisure battery that I have wired a usb socket and battery meter. Its important that you do not completely drain a lead battery. I have had problems with sound quality and ticking noises, not quite sure its correct yet, work in progress!



The pi is at the bottom of the yew tree in the middle of the picture



15:27 CET



Hammersmith, UK: https://locus.creacast.com:9443/mobile_mobile_lisa.ogg

Plan to move stream to LCC.

15:30 CET



Finland: http://locus.creacast.com:9001/kuopio_humisevat_kunnaat.ogg



Sometimes military aircraft maneuvers are taking place.

'Below 0 decibels' with overflight of military aircraft! So setting the levels could be a challenge

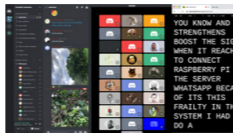

Maria's stream from Crete: https://locus.creacast.com:9443/kalathas_chania_crete.ogg

Mike Bullock's stream: http://locus.creacast.com:9001/florence_ears_in_space.mp3

Here is the bat detector I use, which does heterodyning and frequency division to hear bats in real time: <https://www.batbox.com/product/batbox-duet/>



It has a line out that I will be connecting to my streambox this spring.

Brane Zorman's stream in Ljubljana: http://locus.creacast.com:9001/ljubljana_steklenik.ogg

The stream will be installed at: 46.067070, 14.510632



did you know the work of Tarek Atoui? <http://www.council.art/residency/760/within-infinite-ear>

He worked with a deaf-sonic experience sensitivity, to create spaces and specifics instruments & performance

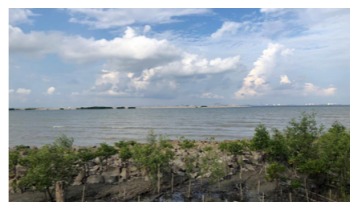

16:28 CET

I'm a PG student in music composition: <https://ainolnaim.wixsite.com/nadabumi>

You can find my field recordings on mangrove forest in Malaysia in the blog

pulau kukup and tanjung piai: <https://www.youtube.com/watch?v=wsdi200jya0>

<https://www.youtube.com/watch?v=G1BbEdtI5NM>

@Roy talking about this writing / listening practice: <https://sthene.blogspot.com/>



16:44 CET

RL Wilson's stream from Ravenglass: http://locus.creacast.com:9001/ravenglass_the_estuary.ogg

lots of sound today has been behind the mic - even my neighbour practising the french horn i first did a broadcast with Tariq Emam for Reveil here

Listening Session

Friday's listening session will be starting very shortly - listen at http://locus.creacast.com:9001/acoustic_commons_workshop_2 and use the #listen-chat to discuss
Mike Bullock
Ooh nice - what is this?
dawn
rain in queensland
Mike Bullock
Ah, Leah's streambox?
dawn
yep
Claudia Martinho
nice
dawn
05:05 AM there
Grant
Rainforest canopy -- Mary Cairncross Scenic Reserve, Queensland
Live stream by Leah Barclay
Mike Bullock
Love it
dawn
do we know what makes the cat wailing sound?
Grant
bushbabies
I don't know which ones
Claudia Martinho
we can hear so clearly all the different sounds, amazing acoustics
Grant
Tech note: this streambox is identical to the ones we were making in the workshops
dawn
[bushbaby picture]
Claudia Martinho
cute!

Grant
The cooing is fruit doves, i think
Roy
These sounds immediately give goosebumps ...
Mike Bullock
what is the big-eyed critter called?
Grant
It's a rainforest remnant not that far from Brisbane - relatively small - so you hear vehicular traffic etc too
le
dawn
galagos or bush babies
Glenn Boulter
that was quite a dramatic downpour just then
PekkaMatilainen
Wow, it's a monkey, not a squirrel :slight_smile:
RL Wilson
This is fantastic!
dawn
that this is a remnant makes it feel more fragile
Glenn Boulter
it has some of that natural / industrial contrast we were talking about earlier
PekkaMatilainen
Pretty much traffic. In general, it is difficult to find a place on earth with only the sounds of nature. Traffic, industry and people are everywhere.
Claudia Martinho
you can really feel how endangered and threatened it is
PekkaMatilainen
And when you think you have found a quiet place, then you will notice

that even planes can be heard from an altitude of more than 10 km.
Grant
The area was preserved from surrounding agricultural development by 4 sisters, I think, in memory of their mother
I may have added a sister
It is operated in partnership with the Sunshine Coast Council.
dawn
it feels important to listen, but harder to convey precisely why
Mike Bullock
yes
Glenn Boulter
We're now hearing a live soundwalk from @magg in Graz
http://locus.creacast.com:9001/acoustic_commons_workshop_2
SteliosGiannoulakis
what we expect to hear in contrast to what we actually hear in our present situation. And how we might mediate this divide. The ears work hard to bring up the information we might need.
Boosted, hard limited, dc removed
Roy
Yes, we re-create a sort of world which make more or less sense and add a new layer, maybe the only layer of reality, a sort of collective subjectivity which we're sharing now with our ears.
SteliosGiannoulakis
it still doesn't work as intended. Some frequencies get lost. I want to squeeze the hell out of it, to extract as much as possible of its essence,

so to speak, exactly what an attentive brain and a set of sensitive ears would do.
Grant
Soundwalk streamed by Margarethe Maierhofer-Lischka from Graz
Mike Bullock
I love this!
PekkaMatilainen
Looking beyond what is essential and how the other person would experience the same as what I myself have experienced on-site. It's a different matter than what's included in the recording.
SteliosGiannoulakis
my question is how i can use the tools to make this transfer work as an experience mediation, as rich and powerful as i might have experienced it in the first place. Loss of detail? Stylization? Condensing and magnifying as an exercise on gain and loss?
artificiality vs reality
what counts?
this stream is great!
PekkaMatilainen
One way is to recreate the recording according to experience. For example, by recording all the parts covered separately and mixing them as a whole according to your own experience and wishes. Lots of work, but the end result is manageable.
Where are we now?
Seaside
maggie
Yes, we can never control another

person's experience, though creating a moment of contact is important
Grant
This is Tabushima Island, off Japan
SteliosGiannoulakis
waves
Grant
It's still night
This is a solar powered satellite transmission by Cyberforest at the University of Tokyo
It's a small island
not far from the coast
with no human inhabitants
Josephine
Ah, but what is reality? our senses have evolved to respond to a tiny spectrum of possible values. 'Perceiving' is something which is both innate, and learned. It's possible that it might take time to learn to make sense of an altered or reduced signal, such as you describe in a compressed recording, just as I took time to learn to make sense of the input from my 22 electrodes laid down on the auditory nerve bed. I'm loving these streams, from Queensland, Graz, and now Tabushima Island
maggie
I always ask myself, how would I hear all those sounds without a description? Soundmaps are a great tool but they also pin down sounds to a certain geography, a context, an expectation...
Grant
The left microphone is in a hole

Mike Bullock
I was wondering about the left channel
SteliosGiannoulakis
right heavy
Grant
I balanced it just a bit
SteliosGiannoulakis
some more to the left maybe
i dare say
dawn
Yes, I'm more a fan of the acousmatic experience
Peter Sinclair
this is the installation that gets knocked out by a hurricane every year
PekkaMatilainen
Our senses are limited, the sense of hearing is perhaps our widest sense in the 2 to 20,000 Hz (10,000x) band. The visual sense only sees the wavelengths (<2x) of the narrow sector and only the narrow band of 400 nm to 700 nm.

SteliosGiannoulakis
works on many levels. some realized consciously, some not
the waves are great by the way
PekkaMatilainen
cooling wind, I would say
dawn
are the shearwaters elsewhere, or sleeping?
Josephine
might we think of the recording instrument having agency in its mediation of the sound? for example in its response to wind,

which we muffle to make it more 'like' what we hear with our ears. anything which breaks the flow of air must have such agency. i'm thinking of how recordings at sea run into problems with sea or wind sounds uninterrupted by landmass
Peter Sinclair
shearwaters never sleep at least they fly by night
Mike Bullock
In a recent workshop discussion about windscreens, Chris Watson said "wind makes noise when it stops." So we use technological extensions to mitigate the sound of wind hitting the mic capsule directly, because it doesn't "sound right" to us, doesn't sound "like wind". Also it tends to efface everything else on the recording for the moment.
dawn
yes seems important to note the tuning of the recorders
Mike Bullock
A prosthesis (windscreen) for another technology (microphone)
PekkaMatilainen
Personally, I think that the recording is like a bystander that does not affect the situation itself, that is, does not break the wind.
My view comes from noise studies.
maggie
Didn't Glenn Gould do that series on the "well-tuned listener"? Se might continue with one on the well-tuned recorder
Mike Bullock
I'll look for that - Gould's radio work

is really brilliant - a lot in there about people reflecting their own identity in their soundscape
maggie
His radio fugues on the identity of the Idea of North are brilliant!
SteliosGiannoulakis
a question on how much work is done in the medium itself vs how much work is done on the side of the receptor. It might be just a matter of intent. An active receptor might find meaning in the most timid of stimuli. A well-tuned transmitter might speak to the most indifferent receptor
Grant
i don't know
if they are there, then at some point they will come out
i think
maggie
Yes, it is always the listeners making the sounds. In a way this is why I don't completely agree with Brandon LaBelle's idea of sonic agency, because it is not the sound itself but the human agency at play.
Josephine
is the difference of intention between the recording and the recording instrument analogous to the difference between luminous and reflected light?
Mike Bullock
Just got this book - will check it out in this light, because on first flush I tend to agree with you
maggie
No because a recorder is a filter

and transformer, while the process of reflection retains some of the original substance.... I would say PekkaMatilainen
Hard questions
Mike Bullock
Yes, I agree - the recording is an inscription - but I think it's interesting the similarities and difference between reflected light and reflected sound
maggie
Yes please correct me or not, I really wondered if anyone else besides me would also see it that way, I was quite bewildered and a bit annoyed in reading because I seemed to find a certain mystification of sound coming into play there
Mike Bullock
I was about to say "the recording equipment doesn't have intention" but then I thought about it and realized that, though it may not be sentient (is it?), nonetheless it inherits the intentions of its designers and makers
PekkaMatilainen
Luminance is the only thing that can be seen, reflected light cannot be seen, only when light comes to the surface and illuminates it.
Josephine
earlier on someone was saying something about what we mean when we say we see a table. well, what we see is reflected light, isn't it?
dawn
this stream begins to sound like a

bowed instrument
each stroke limited by the length of the bow
PekkaMatilainen
We only see the brightness of the surface, not the reflected light.
maggie
Hearing is also reflection and resonance of motions of air molecules and of our eardrums
SteliosGiannoulakis
for me, it is a question of intent.
As a listener, what i am willing to process and what amount of processing power i am willing - or forced - to dedicate to an experience. As a creator and experience provider, what sorcery and delicate manipulation will I lovingly employ to share a vision
Grant
nice
dawn
i think i'm imagining that the glitch changes the phase of the wave
PekkaMatilainen
Yes it does
diffraction slightly reverses the phase
SteliosGiannoulakis
equipment is meant to be ideally transparent? Or to function as a medium that clearly carries an intent, be it the receiver's or the transmitter's
PekkaMatilainen
Yes
This transparency is essential in acoustic measurements.
Although I don't care much about it

:slight_smile:
PekkaMatilainen
Silence
SteliosGiannoulakis
:grin:
Josephine
glad it's not just me
Mike Bullock
Silence here too
Oops or just much quieter!
Josephine
even my dogs were disturbed... they barked
SteliosGiannoulakis
something is going on
Mike Bullock
I hear a fiddle of some kind in the distance
SteliosGiannoulakis
wind on the right, distant rustle?
Grant
[Sorry ppl - seems that the Tabush-ima server shut down just as dawn arrived..]
This is a stream from Jeju Island by Jiyeon Kim and Gangil Yi
It is installed in a wall made of large stones
under a fruit tree
PekkaMatilainen
music played on a pentatonic scale
Grant
at Culture Space Yang
Georo village, Hwabuk-dong, Jeju-do
Jiyeon Kim and Gangil Yi are sometimes known as weatherReport
SteliosGiannoulakis
i thought it was in my head...
Mike Bullock

(If anyone is listening to my stream I am messing with it a little - will be back online soon)
SteliosGiannoulakis
i go to bed now, love you, speak to you soon :slight_smile:
PekkaMatilainen
Good night :slight_smile:
Mike Bullock
Good night Stelios! We will be in touch this week.
PekkaMatilainen
Is that instrument some kind of wind organ?
Roy
Bedtime for me too, i'll be back from times to times this week-end, i'll send a documents and links too, thanks a lot for these moments.
PekkaMatilainen
Mixing?
Mike Bullock
Thank you Roy!
I was just out chipping my stream-box out of the ice, because I felt it was important to work on it right now, in -10 C... This is a sign of how motivating this week has been, that I had to go do this now :slight_smile:
The windscreens are still out there, frozen into the snow.
I'm going to try turning on the Wi-Fi and powering it with a battery, to give myself more placement options.
PekkaMatilainen
Here only -3 C
Grant
This is a forest in Chichibu, Japan
Late good nights to Roy and Stelios

Mike that is motivation for sure
Mike Bullock
haha yes motivation to get inside soon
Josephine
bravo - here is a balmy 1 C
Grant
ha yes -10 is no joke
i think in Japan it s maybe not very cold but you can hear the weather systems churning through the streams
Josephine
we had those sort of temperatures in the winter of 2010 and maybe once again a few years ago... but you don't forget the experience
Mike Bullock
beautiful
Josephine
yes - resistance to the air movement from the trees?
Grant
i guess what people were saying above earlier, about the way masses of vegetation counter and reveal the wind
but also, at a different scale, perhaps, the sense of spring engaging
dawn
yes
springs
Grant
ha yes
dawn
i was just remembering watching branches thru a scope
amazing how springy they are for a more enlightened take: <https://www.ncbi.nlm.nih.gov/pmc/articles/>

PMC4298005/
PubMed Central (PMC)
A tree swaying in a turbulent wind: a scaling analysis
A tentative scaling theory is presented of a tree swaying in a turbulent wind. It is argued that the turbulence of the air within the crown is in the inertial regime. An eddy causes a dynamic bending response of the branches according to a time criterion. ...
Grant
ah yes - watching the branches of different trees from the top of the house, they each respond in their own way, and also shed water drops in different ways, it seems, on the stream
i think this whole theme of wind encountering and animating the landscape is important to Bashō - the sense of energy it brings and of course the sounds it generates
PekkaMatilainen
Personally, I enjoy the hum of the trees in the wind, sometimes I listen to the trees and try to guess what species is everywhere.
Grant
i find in the autumn Walney is where I hear the first sign of the switch to autumn, with heavy masses of wind starting to move, the way a clutch engages
often when it is still warm and feels like summer in london
and spring it feels like is revealed in the cyberforests

these swirling masses of air through the trees
Mike Bullock
Interesting, I feel like I can hear the approach of fall around here better than I could in cities. And definitely was hearing the approach of winter, as the deciduous trees became gradually more bare and the tree sounds became mostly evergreen
Grant
and birds arriving sparsely at first
yes i agree - in a city it feels more processed maybe
Mike Bullock
Here we get flocks of Canada geese migrating south in the evening, as winter approaches
Grant
slightly at arm's length
Mike Bullock
Fewer trees overall too, in most cities, and a lot fewer evergreens where I've lived
Grant
ah yes geese
Japan is so long North to South. The mics in Hokkaido are under quite deep snow still, while the South is sub tropical i think
Mike Bullock
many geese! They seem to fly every which way but in general they trend southward :slight_smile: That was just in autumn though. Now it's some owls and lots of smaller birds
Such interesting geography - good point about Japan being so different from north to south - and yet it's all

united, I suppose, by proximity to the ocean, with mountains in the middle? Never gone, would really love to spend some time there
Grant
Ah owls!
In Hokkaido they have some huge owls - i slightly hope to hear them on the stream but i never have what is this calling now?
Mike Bullock
I will try to catch our local owls tonight on an audiomoth
Grant
the forest is so subdued compared to in May
are they Great Horned Owls?
my N American owl knowledge is v limited
dawn
need to get to barrow market, they have a good selection
Mike Bullock
possible - I will look it up
Grant
flash owls maybe
Mike Bullock
possibly a barred owl
Grant
ah yes
I hope the cyberforest streams will be ok after Kaoru Saito retires
i think they re in a slightly precarious position
Mike Bullock
Just listened to a clip of a Great Horned - could be that too
The cyberforest stream is a treasure - one of the OGs of streamed ecoacoustics

Grant
for 2021 : more owls, more bats
Mike Bullock
yes!
Silent night hunter theme
dawn
more decent water based streams
could be good too
Mike Bullock
Yes
Stream streams
Grant
i agree - even this is technically
really something - to convey these
things so eloquently - movements of
air - i mean..
dawn
i feel like i understand the air better
since i started swimming in the sea
Grant
like currents..?
Mike Bullock
I remember on the mountainside we
discussed the idea of a stream of
the various drinking spots - places
where water bubbled up from the
mountain, differentiated between
human-safe and non-human-safe
dawn
yeah
and flows
Grant
you swim into those warmer or
colder areas and you are amazed
they don't just mix together and
even out
but they don't
dawn
the no ground thing takes some
getting used to
Mike Bullock
As a kid, It was a way that we could

tell we were swimming a little too
far out in the ocean - feeling the cold
water coming in under the warmer
layer
Grant
i think the fonts idea is good still - i
want to get in touch with those guys
at Camp FR again..
Mike Bullock
Mike Bullock
Yes, I think they might like the idea
Grant
ah yes - the depth
Mike Bullock
It was all kind of cold, it was more
like when the colder water arrived
under the cold water
But yes, why is it so easy to feel the
difference, they don't just mix?
Grant
the forest also has depth, it seems, i
agree - swirling
Mike Bullock
Mike Bullock
@dawn where do you swim in the
sea?
Grant
well the currents both move against
and float on each other, i think..
dawn
canaries recently
Grant
but @dawn is the expert
dawn
car radio picked up stations from n
africa
Mike Bullock
Mike Bullock
cool!
Grant
and then you went to the canaries
or..
dawn
apparently near berwick in n eng-
land is good for snorkelling

Grant
in the canaries, the radio..
in what sense?
'good' in what sense?
dawn
accessible spots, clear water, range
of species
Grant
good answer
dawn
granted it is rather cold
Grant
Grant
u sound authoritative - is it a river?
berwick on tweed?
or a garment?
dawn
northumberland coast, near the
tweed yeah
Grant
ah right
Mike Bullock
Mike Bullock
Is it cold enough to swim in tweed?
:smile:
Grant
ha
i m getting bit tired and wondering
if half past might be time to wind
down from here..
and hand you over to the server
directly
dawn
dawn
it's been a good stretch
did you eat dinner at all this week?
Mike Bullock
Thanks for all your work!
Grant
i really appreciate the relay of
these little gestural things : a small
upward inflected call, a little flurry of
crackles..
i am concerned about the carbon
footprint - it still feels like a humane

practice
dawn
sounding like morning proper
Grant
yes - kind of opening out
the sea is that blue you only get on
google maps
full of promise
perhaps
actually i haven't eaten - that's a
good point
Grant
Grant
thank you
Mike Bullock
A pleasure to meet lots of new
people and get loads of ideas.
Grant
for sure - very nice
Mike Bullock
FWIW I just moved my streambox
to the other side of the house where
it should get more birds tomorrow
AM - running over Wifi, powered by
a USB battery.
Grant
Grant
we will work on this regular work-
shop meet i think
cool - i ll listen in
Mike Bullock
Sounds good.
PekkaMatilainen
This was a really gratifying experi-
ence, good to move on. Thanks to
everyone :slight_smile:
Josephine
Grant
though I haven't spent as much
time as I would like, nor contributed
much, I have found this week
enormously stimulating and inspir-
ing - thank you all, and I hope to see
you again soon. have loved every
moment

Grant
Thanks very much, Pekka
It's been great to have you around,
Josephine - thank you
Alangus
Thanks for another great evening
of listening and for all your work.
Its been an inspiring week, really
enjoyed it.
PekkaMatilainen
Thank you Grant
Grant
A really nice collaboration - thanks
@dawn - thanks all
I will sign off i think - good night
dawn
gn all
Mike Bullock
Eats something!
Alangus
Ive not been able to contribute
any feeds but Ive made a big stack
of sound drawings, its been very
enjoyable. Night all.
Mike Bullock
Good night all, and merci!
PekkaMatilainen
Good night

